





# Technical Information

---

Necessary data to determine the type of cable chain	page 12
---	---------

---

Placement of cables/hoses in the cable chain	page 13
--	---------

---

## Mounting Variations

---

Chains placed horizontally	page 14
----------------------------	---------

---

Chains placed vertically	page 16
--------------------------	---------

---

Chains with circular motion	page 17
-----------------------------	---------

---

## Going Further

---

Self-supporting capacity	page 18
--------------------------	---------

---

Determining the length of the chain	page 19
-------------------------------------	---------

---

Vertical applications	page 20
-----------------------	---------

---

Horizontal applications (side-mounted)	page 21
--	---------

---

Long horizontal travel distances	page 22
----------------------------------	---------

---

Guide channels for sliding chains	page 24
-----------------------------------	---------

---

How to install the cable chains in the guide channel	page 25
--	---------

---

Rotating horizontally	page 26
-----------------------	---------

---

Rotation with Robot type chains	page 28
---------------------------------	---------

---

Support roller units	page 30
----------------------	---------

---

Way of mounting end brackets	page 31
------------------------------	---------

---

Guide channel	page 32
---------------	---------

---

Split cross pieces from the Heavy/Sliding series	page 33
--	---------

---

Materials used	page 34
----------------	---------

---

2



# Necessary Data to Determine the Type of Cable Chain

The choice of cable chain should not only be based on a mathematical calculation of certain factors but should consider and analyse carefully all the available data. The following information will be provide a basic help in making the right decision.

Thanks to thirty years of experience in this sector we have a highly competent technical staff which is at your disposal to help solve any problem relating to the use of cables in any kind of application.

To request a personalised project please fill out the form found on page 257. It will be a pleasure for us to find an immediate solution to your problem.

2

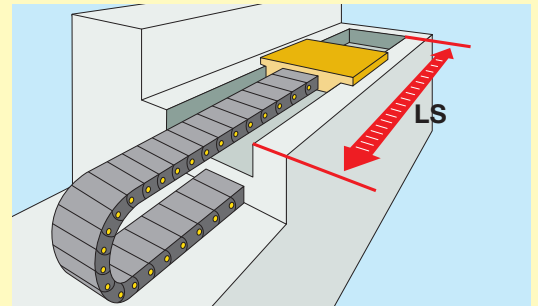
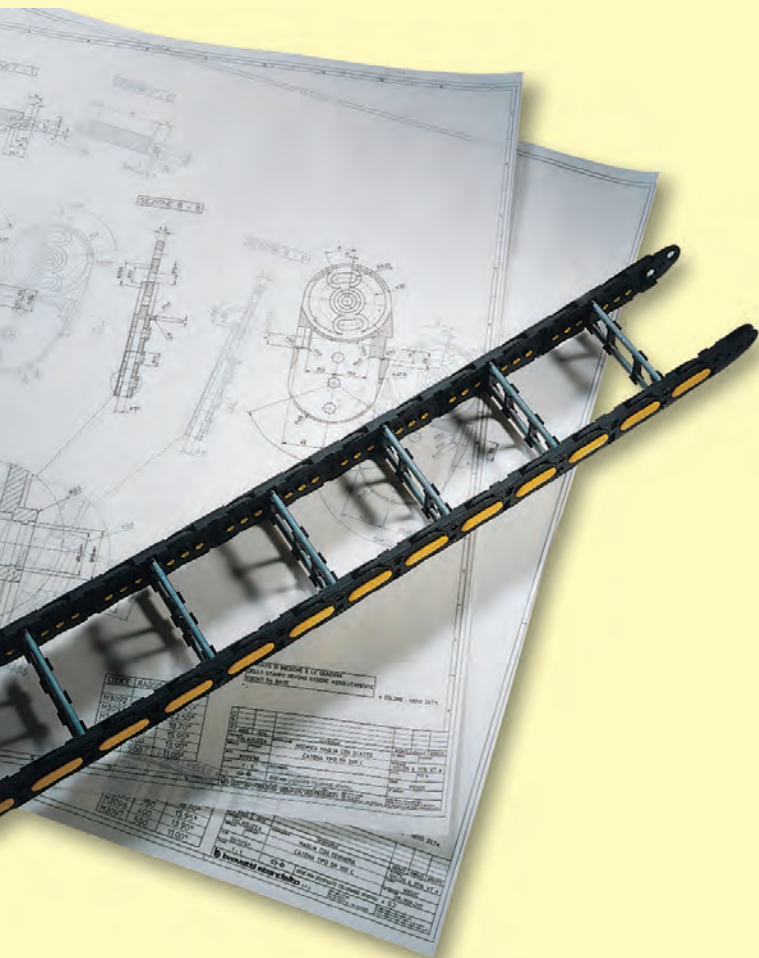

Determining the length of the travelling distance LS.

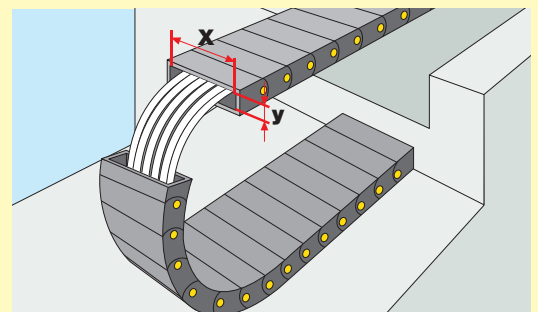

The dimensions of the cable chain in relationship to the dimensions of cables/hoses.

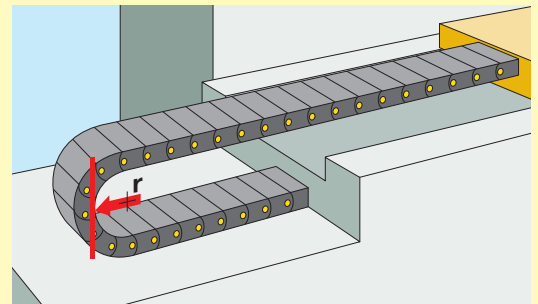

Determining the radius of curvature of the cable chain in relationship to the flexibility characteristics of cables/hoses.

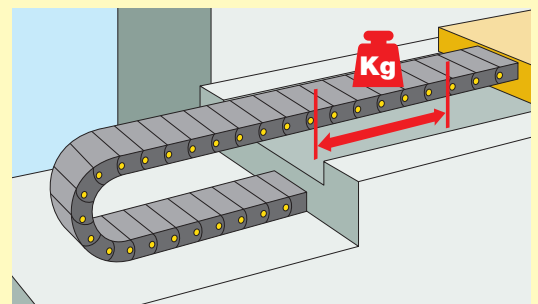

Verifying the self-supporting capacity of the cable chain in relationship to the weight per metre of cables/hoses.



# Placement of Cables/Hoses in the Cable Chains

To guarantee that cable chain functions properly and to avoid any damage to the cables/hoses within, certain criteria concerning the placement must be followed:

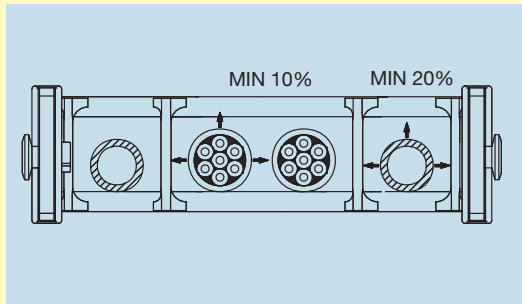

For electric cables a clearance of at least 10% between the placement of the cable and its diameter has to be guaranteed; for hydraulic hoses the clearance should be at least 20%.

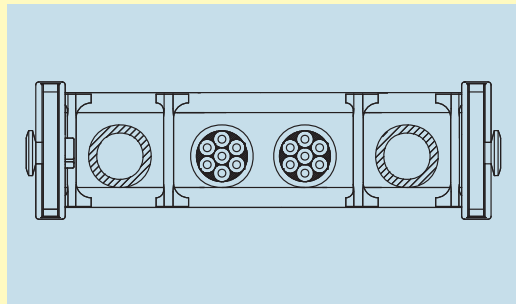

Avoid placing cables/hoses that have different sheath finishes so that friction can be eliminated. (e.g. hydraulic cables and hoses).

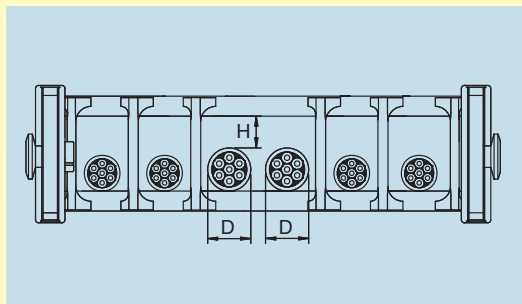

In the application of several cables/hoses it is preferable to avoid them rubbing each other by placing them singularly in the appropriate space and separating them from each other by the separators. If this is not possible, verify that the internal space does not allow the rubbing of the cables/hoses. ( $H < D$ ).

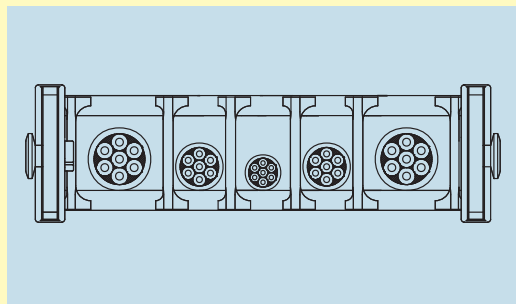

Place cables/hoses in a symmetrical way according to their dimensions and weight placing the largest and heaviest externally and the smaller and lighter internally.

For further information on how to install cables/hoses see page 254.

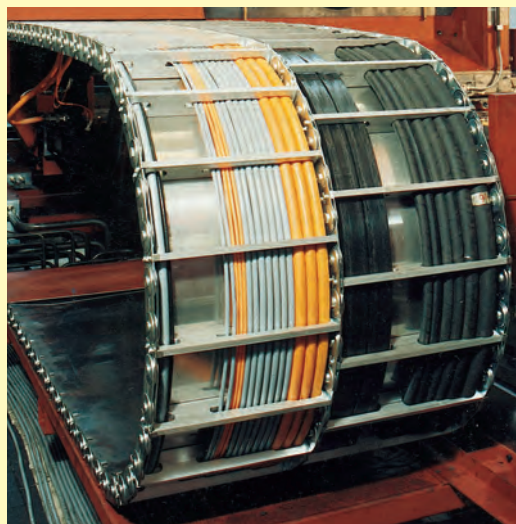

A 30 chain in steel with three bands and separations between electric cables and hydraulic hoses..

# Mounting Variations

## Chains Placed Horizontally

Brevetti Stendalto chains, thanks to a large range of models and versions, satisfy many requirements in variety and combination of motions. On this page the various combinations of mounting are listed.

For further information about realising a personalised project please contact our technical department. They are at your disposal to resolve any specific problems you may have and can design according to your particular request.

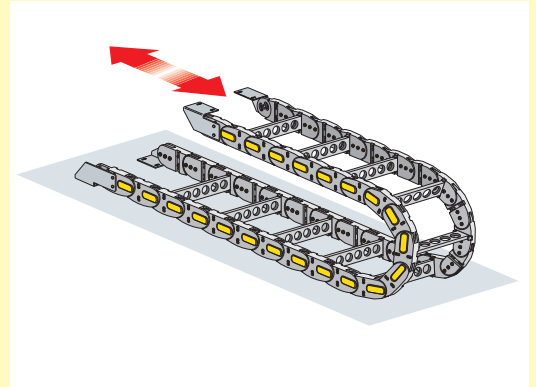

*Horizontal with mobile point above.*

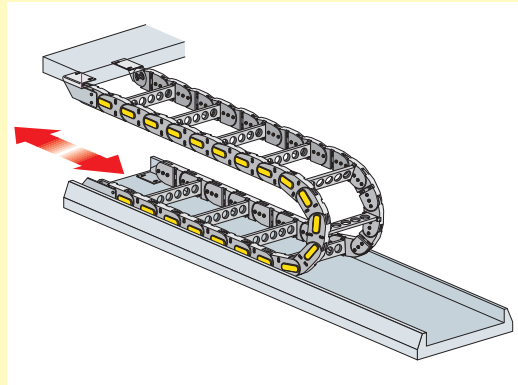

*Horizontal with mobile point below (to the car).*

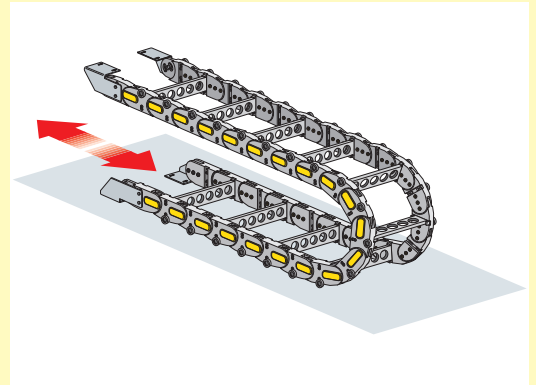

*Horizontal with mobile point below.*

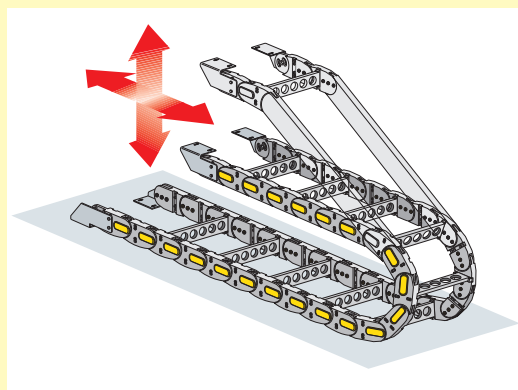

*Combination of both vertical and horizontal movement.*

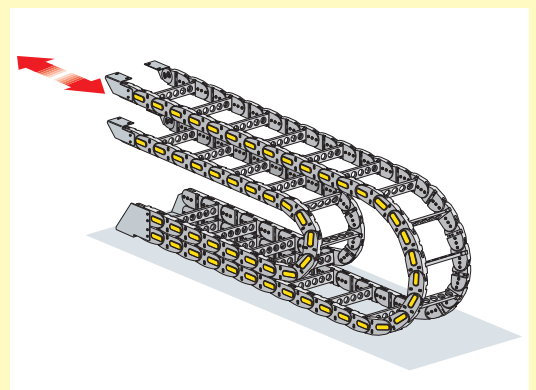

*Superimposed chains.*

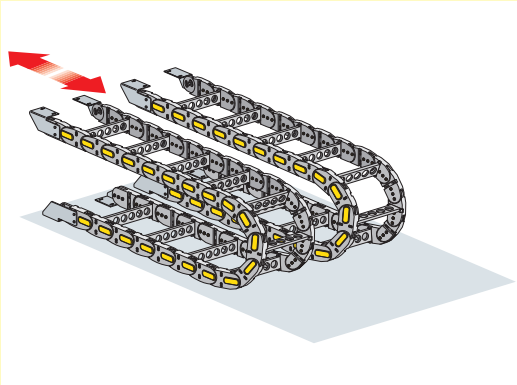

Chains positioned in parallel.

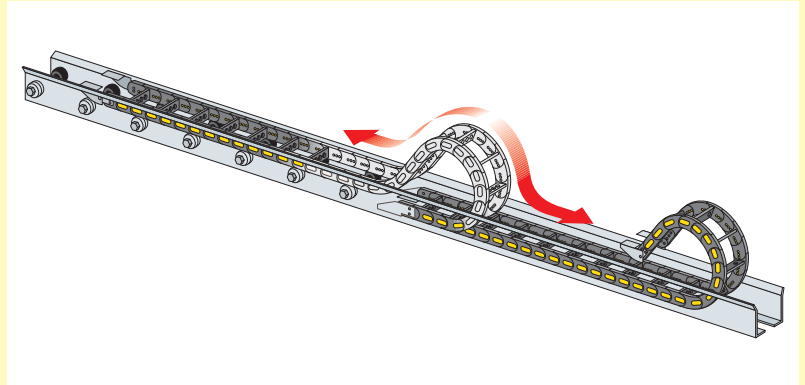

Long horizontal - 1 chain  
(see page 22).

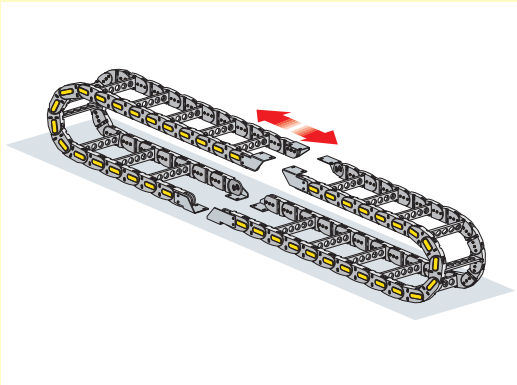

Chain making a ring configuration.

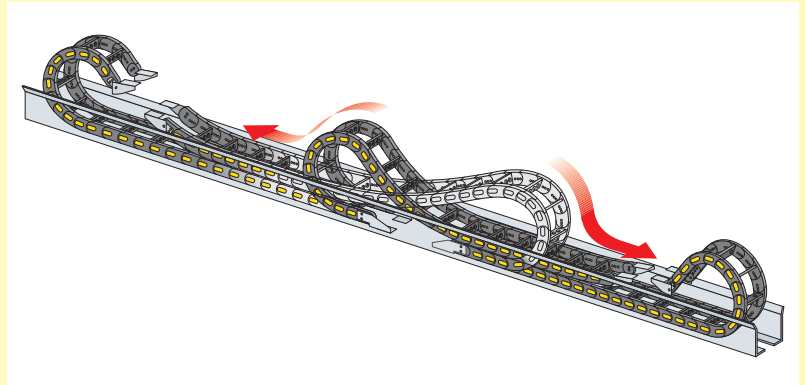

Long horizontal - 2 chains  
(see page 22).

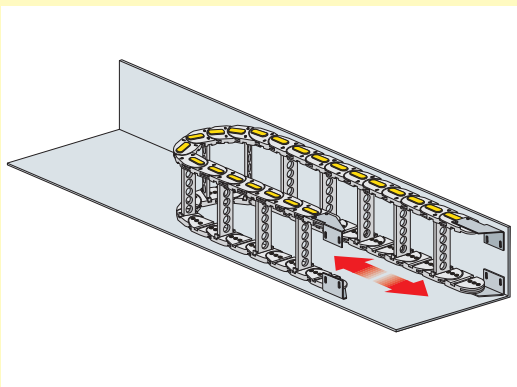

Horizontal with chain mounted on its side  
(see page 21).

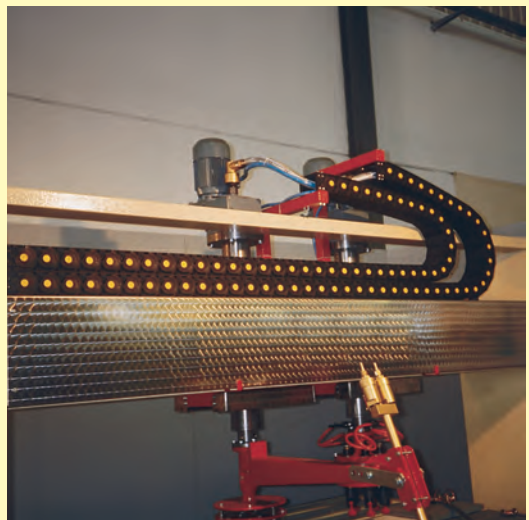

Model 700  
chains in nylon  
superimposed on a machine  
which works with marble.

# Mounting Variations

## Chains Placed Vertically

Brevetti Stendalto chains also provide answers to problems concerning vertical motion. Thanks to their particular design Brevetti Stendalto cable chains can also be used in applications with extremely long travel distances.

2

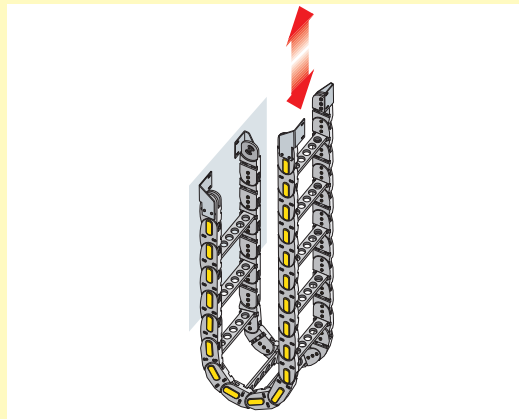

Vertical with curve below  
(see page 20).

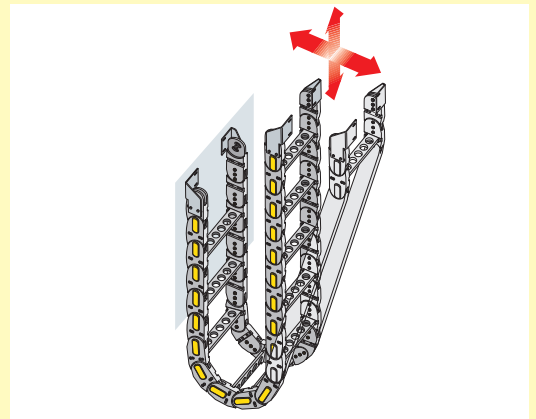

Combination of both vertical and horizontal movement.

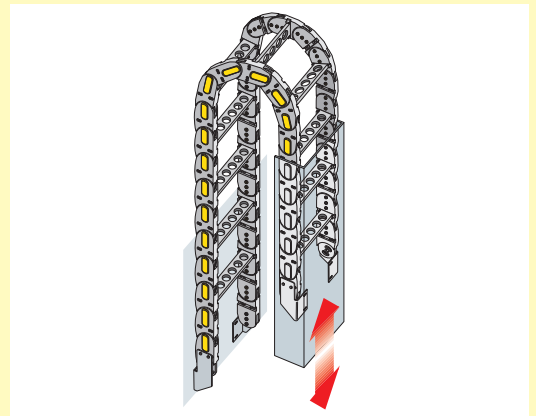

Vertical with curve above  
(see page 20).



355 vertical with curve below  
nylon chain on machine tool.

### Chains with Circular Motion

The problems regarding circular motion are easily resolved with the chains from the ROBOT series, an exclusive Brevetti Stendalto product. It is also possible to use the chains in counter-rotation configuration by mounting them on their side.

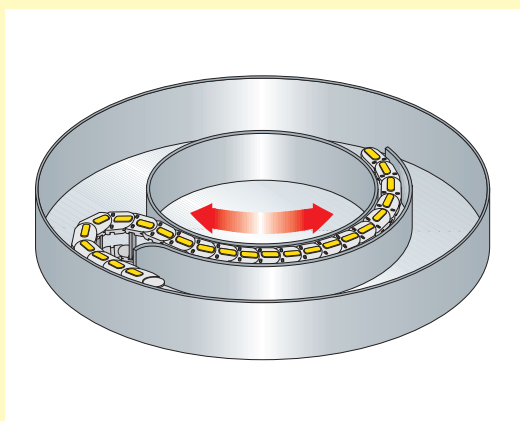

Chain for circular movement - 1 chain  
(see page 26).

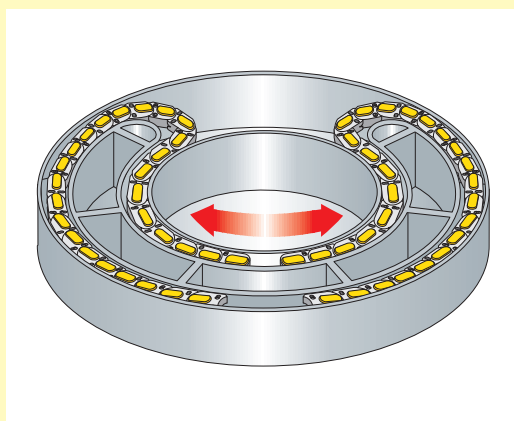

Chain for circular movement - 2 chains  
(see page 26).

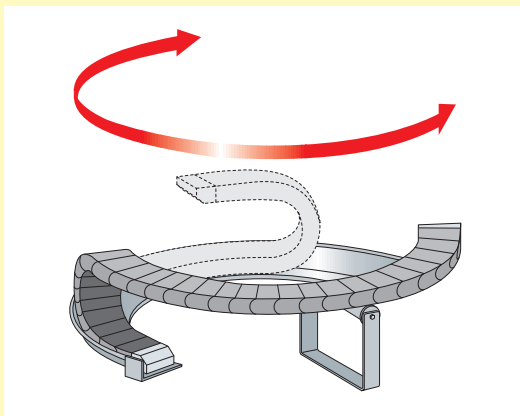

ROBOT type chain for circular motion.  
(see page 28).



Robot for welding with chains in nylon.



# Self-Supporting Capacity

A fundamental element in cable chains is the pre-set Z (Fig. A).

This determines the self-supporting capacity, a characteristic which allows the cable chain to support not only its own weight, but also the weight of the cables/hoses placed in it and to keep its parallel or slightly curved upward position (Fig. B).

The diagram of self-supporting capacity (Fig. C), indicates the weight relation of cables/hoses per linear meter to the lengths of self-supporting chain travel. The red-area indicates the difference between min/max chain widths, while the widest version has the lowest self-support capacity. With the application of cable chains with  $\frac{LS}{2}$  and weights not included in the area of the diagram of self-supporting capacity, it's

necessary to use the appropriate support rollers (see page 30), in order to confirm chain reliability in exceptional applications.

All the H-heights reported into this catalogue are not including any Z-value due to the preload, therefore, whenever limitations to the maximum allowable height are required, you should refer to Brevetti Stendalto's Technical Dptm.

Brevetti Stendalto chains, thanks to their specific construction, reach remarkably high values of self-supporting capacity and acceleration with long periods of motion, reaching millions of cycles.

For particular applications (e.g. vertical travel), the chains can be provided without pre-set.

2

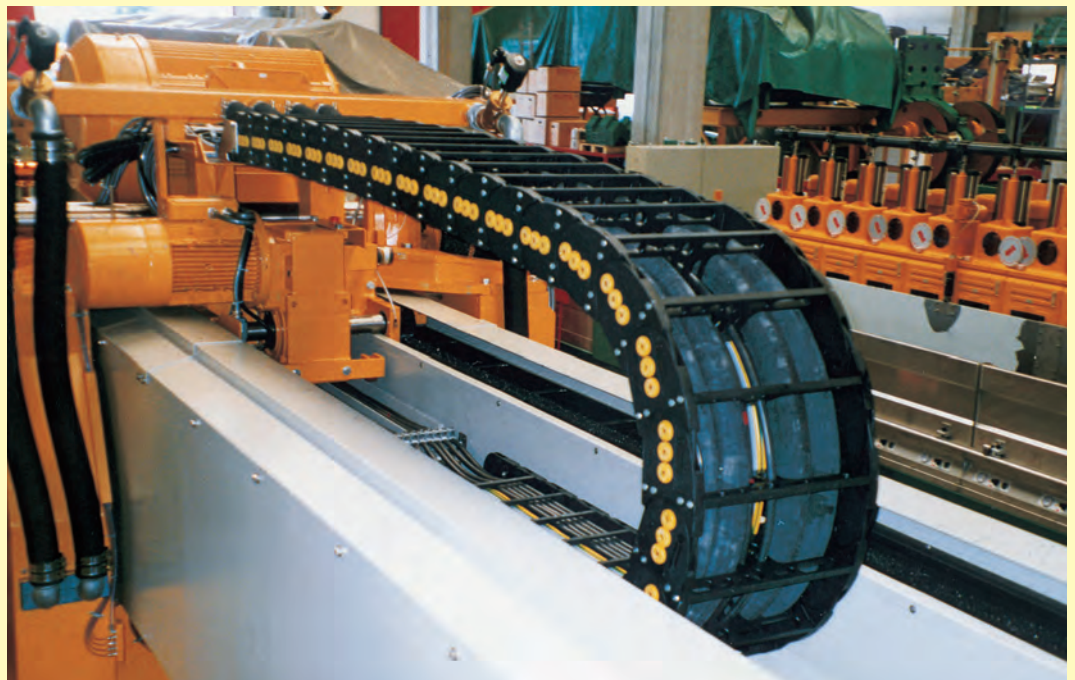
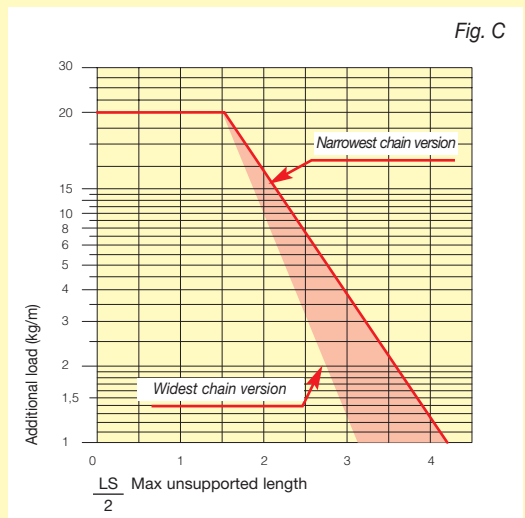
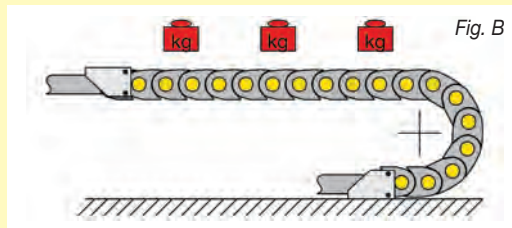
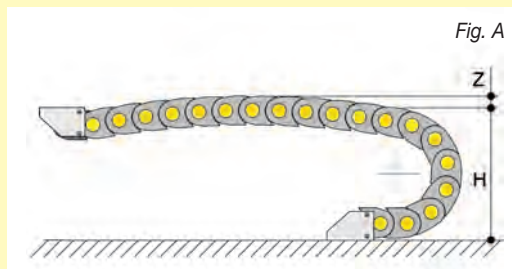

Nylon chain, type 310, in a self-supporting state.

# Determining the Chain length

## Fixed point at the centre of total travel.

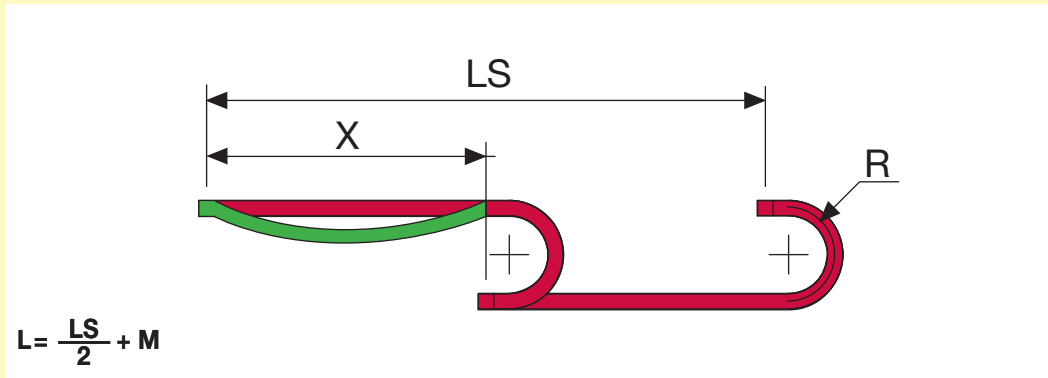

The chain length (**L**) is calculated by summarising the half stroke  $\frac{LS}{2}$  to the nominal value (**M**) of the bending radius. The value is then rounded up the multiply of the chain's pitch for nylon cable chains and to an odd multiply for steel chains.

## Fixed point not positioned at the centre of total travel.

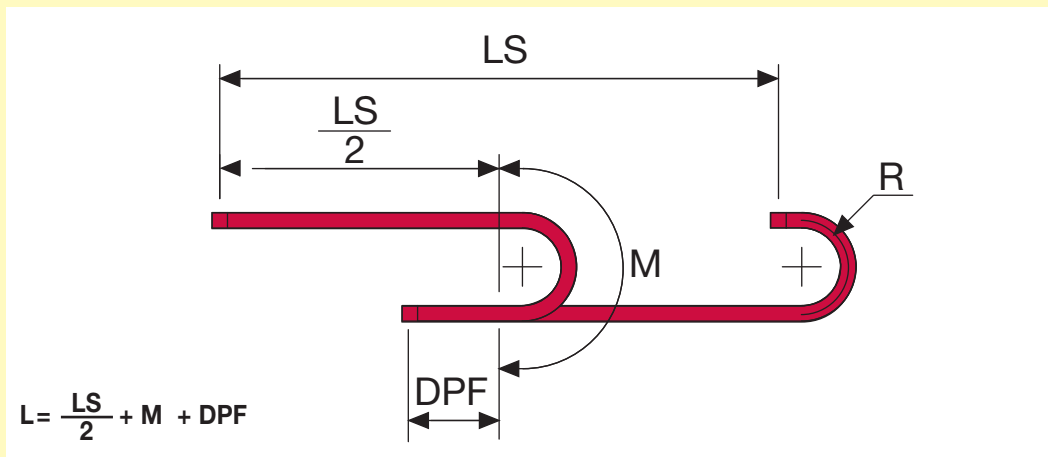

The chain length (**L**) is calculated by summarising the half stroke  $\frac{LS}{2}$  to the nominal value (**M**) of the bending radius and the distance (**DPF**) from fixed point to centre of total stroke. The value is then rounded up the multiply of the chain's pitch for nylon cable chains and to an odd multiply for steel chains.

Where:

$L$  = Length of chain

$\frac{LS}{2}$  = Half travel distance

$M$  = Length of curve  $(\pi \times R) + (2 \times P)$

$DPF$  = Distance from fixed point to centre of total stroke

$P$  = Pitch



# Going Further

## Vertical Applications

The problems related to vertical applications are solved by using Brevetti Stendalto cable chains. It is however necessary to respect the following:

The use of standard cable chains for vertical applications could result in difficulties due to the pre-set. we therefore recommend to specify: *“without pre-set for vertical applications”* when ordering. By doing this the cable chain will be delivered to you without pre-set.

2

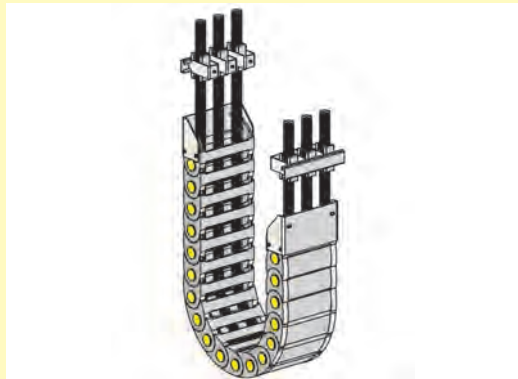

*The placement of the cable/hoses is very important to ensure the application works properly. Cables/hoses have to be fixed at both ends using the appropriate accessories so as not to make their weight disturb the cable chain. In this type of application the cable chain should only guide the cables/hoses during their movement.*

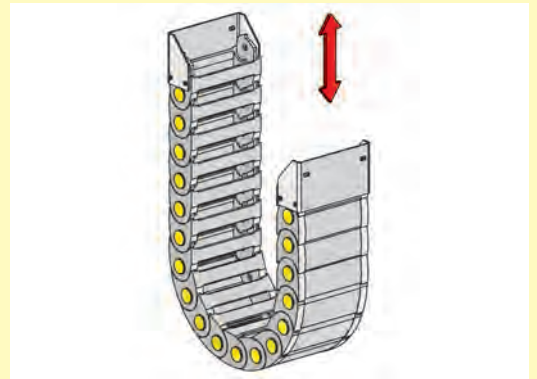

*If the application only concerns one vertical movement the cable chain does not need any particular support.*

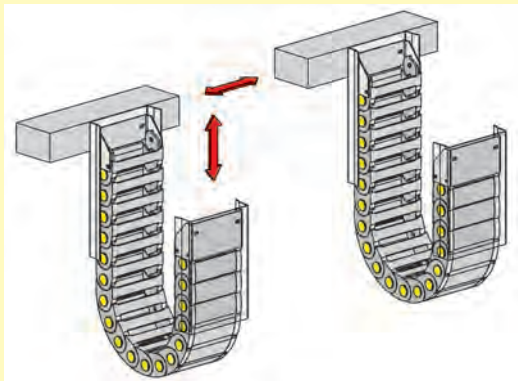

*If the cable chain also moves across and/or longitudinally, certain measures have to be taken laterally. For special applications, frames with completely closed guiding systems are available.*

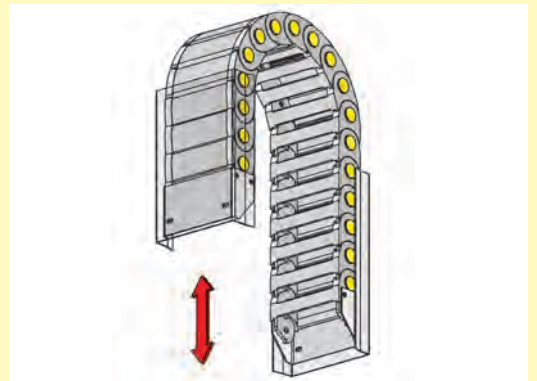

*When applying the cable chain in this way some support is needed to avoid the chain to unbalance itself outwardly. Generally the cable chain must be supported both on the fixed and mobile points.*



# Going Further

## Horizontal Applications on Their Sides

Brevetti Stendalto cable chains can be mounted on their sides.

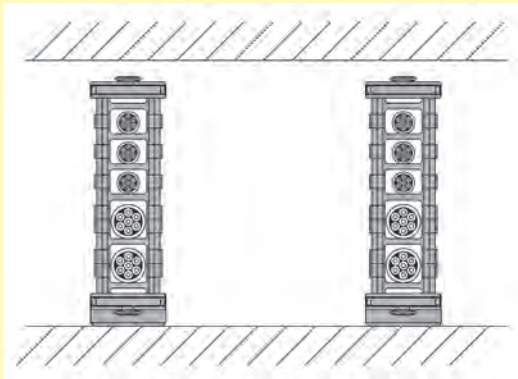

This kind of mounting becomes necessary when there is a limited space upwards and mounting the chain normally would take up too much space.

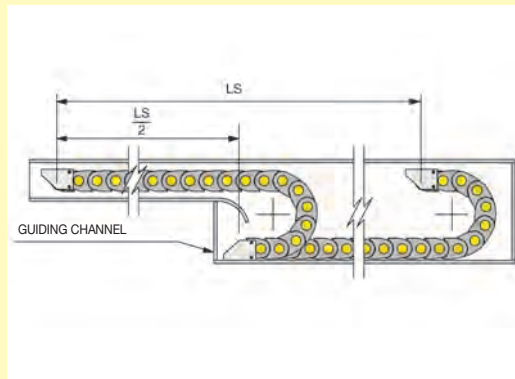

For particularly long applications a guiding channel can be designed.

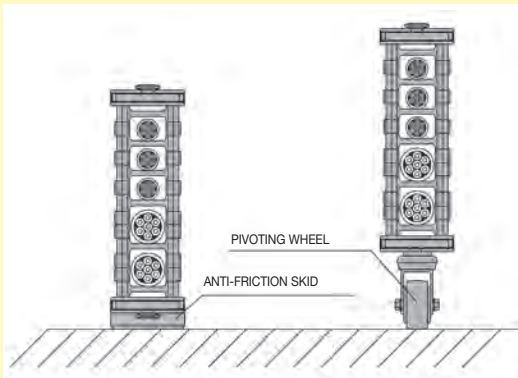

To make the movement easier and to reduce any friction on the cable chain, special changeable anti-friction skids or pivoting wheels have been designed.

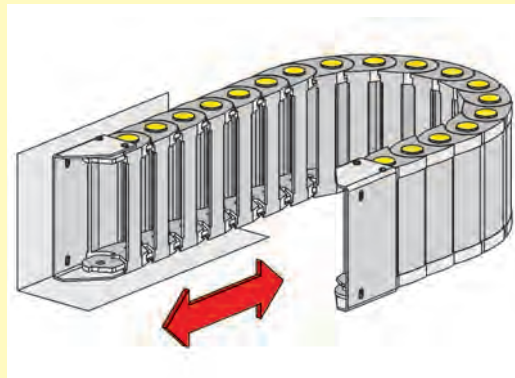

If there is no possibility for a plane to support the cable chain during its movement, Brevetti Stendalto chains can be applied without support taking into consideration the following factors:

- total travel distance LS
- added weight
- velocity and acceleration
- frequency of usage

For this kind of application, it is recommended to discuss with our technical office.

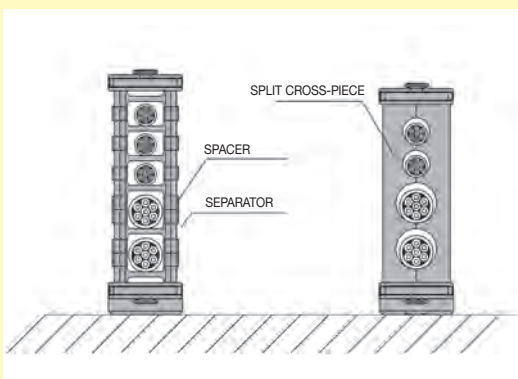

Particular attention should be drawn to determine the section of the cable chain, in fact, the mounting on its side of the chain means that cables/hoses have a tendency of bunching towards the ground and being squashed.

To avoid this, there are special spacers which are positioned between the separators or otherwise special split aluminium or PVC cross pieces to be applied.



# Going Further



## Long Horizontal Travel Distance

Cable chains are used more frequently on long travel distances as a valid alternative to the traditional systems of conductor bars or to festoon systems, and offer the following advantages:

- The possibility of the combined transportation of hydraulic cables/tubes.
- The possibility of use also in critical environments (humidity, textile dust, negative chemical and atmospheric components etc.).
- High velocities and values of acceleration.
- Notably shorter installation times.
- Drastic reduction in the time taken for maintenance.

Sliding series is the integrated sliding skid which permit the chains to slide on themselves reducing the friction due to the special polymers used.

The dimensions of the skid allow the chain to keep itself stable in applications with high velocities.

On request it's possible to produce cable chains with special polyamides for applying in particularly aggressive environments.

The triple pins guarantee more reliability and strength even in applications with the added weight being very high. The chains in the Sliding series have been tested using torsion, wear and tear tests passing the tensile yield stress with extremely good results, above high normal values (e.g. 318 21000 N).

The special aspect of the cable chains in the

*In these applications, the chain without self-supporting capacity, slides in it's own guiding channels. For the first half of the travel distance the chain slides on itself, whilst in the second half it is supported by it's own rollers or plates for sliding.*

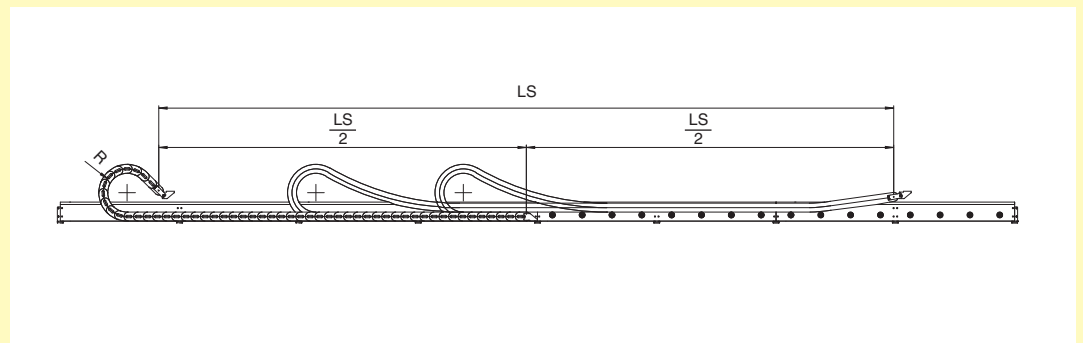

*In double chain applications, the chains slide on themselves in both directions.*

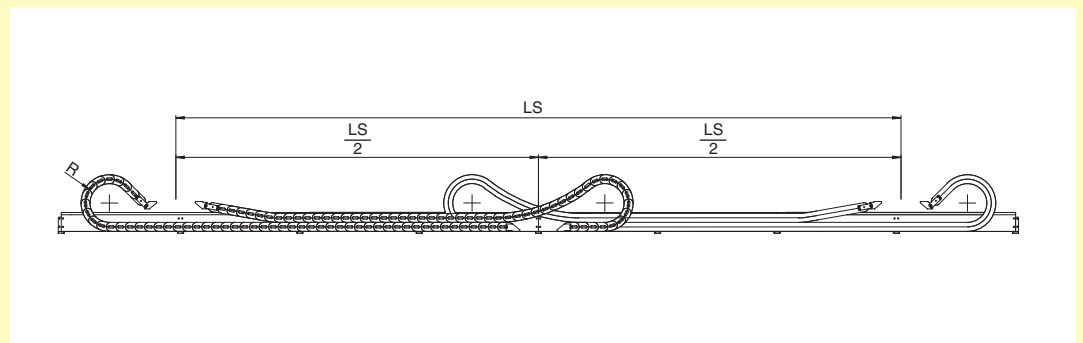

*A particular of the skid in the sliding of the chains in the Sliding series.*

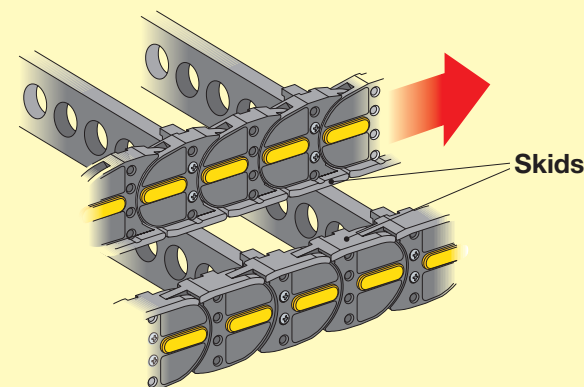



318 type chain.



318 type chain.



# Going Further

## Guide Channels for Sliding

For good results when using cable chain in an application with a long travelling distance it is necessary to respect the following instructions when installing the guide channel for sliding:

2

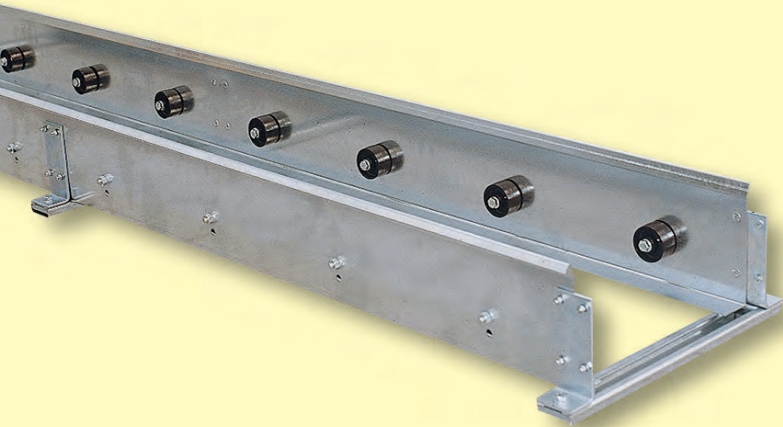

Guide channel for chains of the Sliding series.

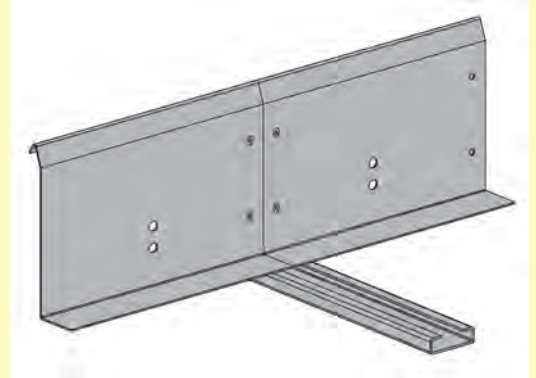

Verify that the sides are aligned properly to avoid any internal edges in the guide channel which could disturb the cable chain's route.

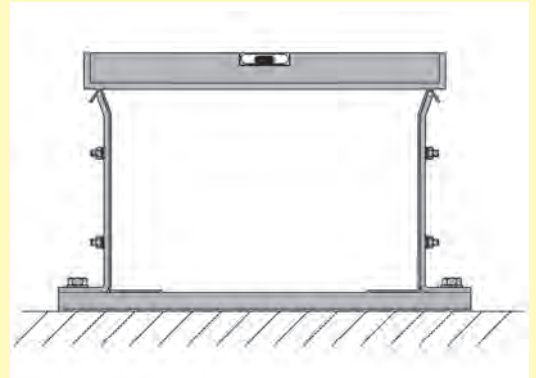

Verify that the plane on which the guide channel for sliding is mounted is perfectly aligned and smooth.

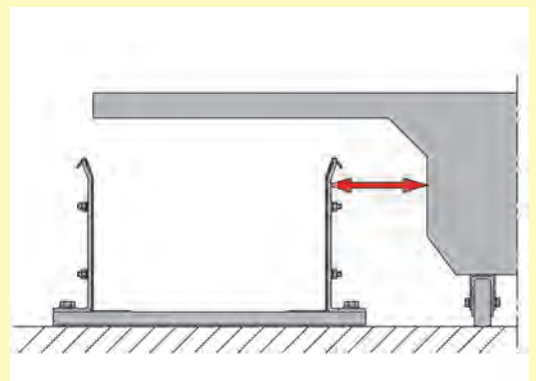

Verify that the distance between the guide channel for sliding and the towing arm is the same for the whole travelling distance.

## How to Install the Cable Chains in the Guide Channel

For a perfect installation of the cable chain in the guide channel you should take the following steps:

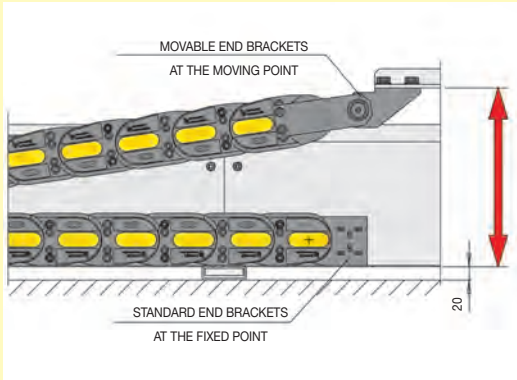

Install the cable chain with the standard end brackets at the fixed point and with the movable end brackets at the moving point respecting the height listed in the catalogue.

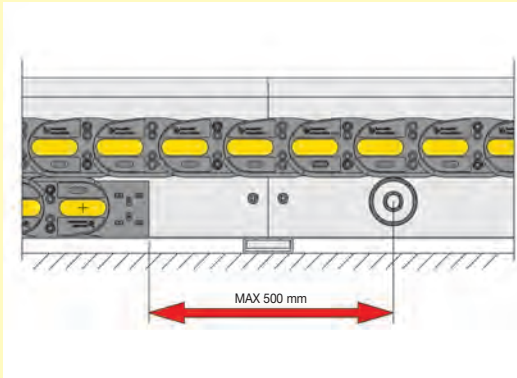

Reduce as much as possible the distance between the fixed point of the cable chain and the starting point of the rollers or sliding plane.

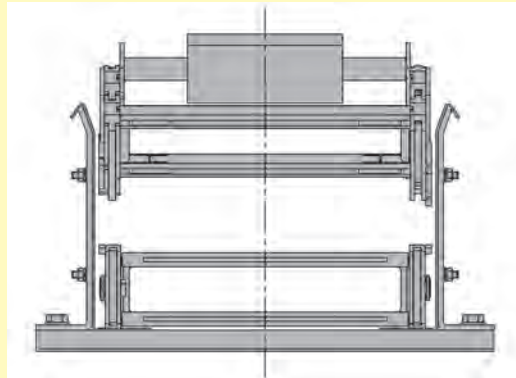

Install the mobile point of the cable chain aligning it exactly to the longitudinal travel distance in such a way so that during its movement it does not touch the internal part of the guide channel (Fig. A).

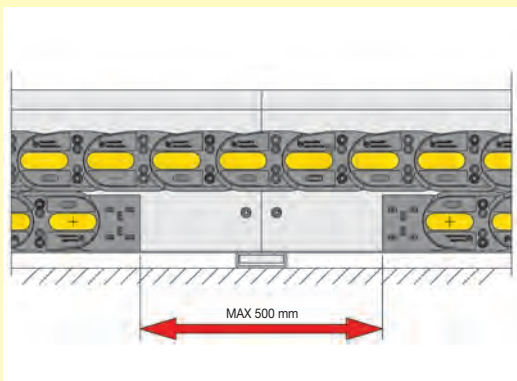

In the case of a double chain application ensure that the distance between the two fixed points doesn't exceed 500mm.

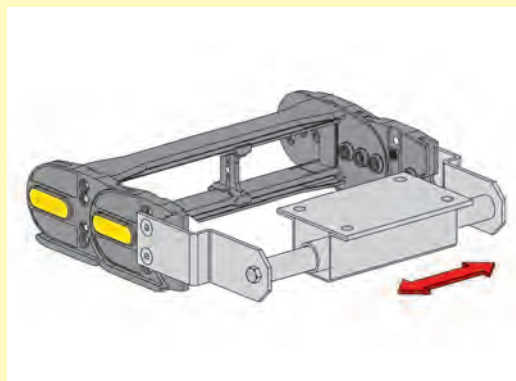

To facilitate this operation Brevetti Stendalto has developed and created a special movable end bracket which guarantees a perfect alignment between the chain and the towing arm (Fig. B).



# Going Further

2

## Rotating Horizontally

For certain applications it is necessary that the cable chains perform an opposite movement from that determined by the radius of the curvature (counter-radius chains). All Brevetti Stendalto chains, except those from the

PROTECTION series, can be supplied with this counter-radius. Generally the chains with counter-radius are used to resolve the problems relative to rotations where, in this case, it would not be possible to use cable chains from the ROBOT series.

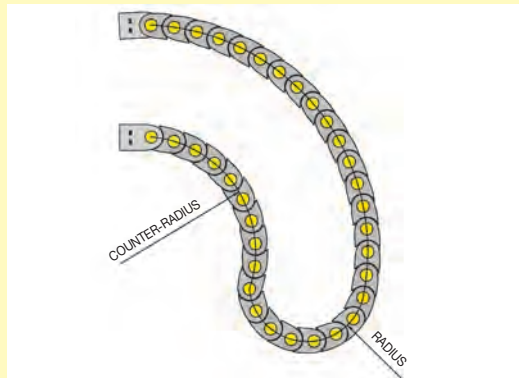

With the use of counter-radius chains it is possible to create rotations both on small and large equipment (e.g. parabolic antennas, rotating tables, cranes, telescopes).

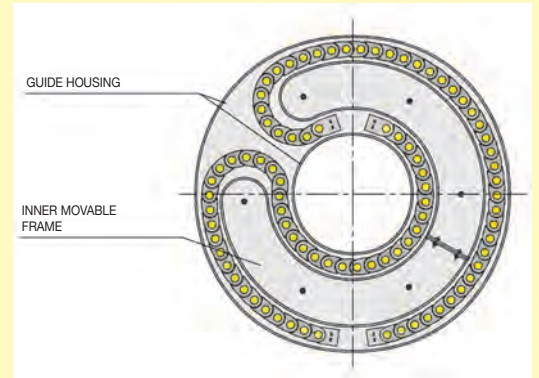

For applications with rotations over 180° it is necessary to use two cable chains. For a correct usage they should be guided both internally and externally. A special inner movable frame, mounted on anti-friction skids or pivoting wheels in combination to the guide housing guarantees the rotation.

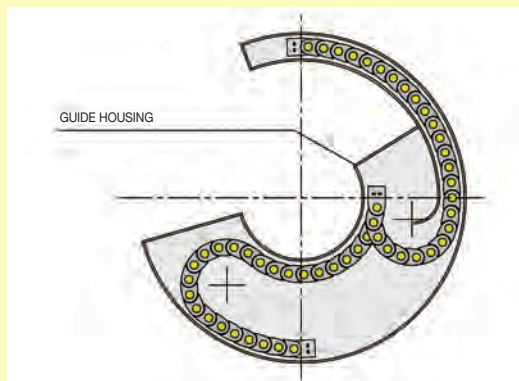

For applications with rotations up to 180° it is possible to use only one cable chain. For a correct usage it should be installed with a guide housing.

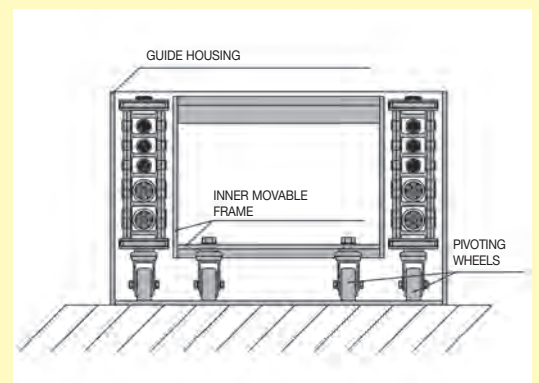
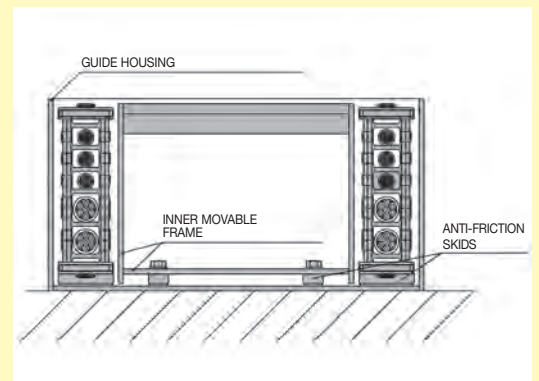

To facilitate the sliding and reduce the friction of the cable chain, special changeable skids or pivoting wheels are taken into account. With this kind of application it is also possible to rotate vertically. Seen the particular aspects of these applications we advise you to contact and consult our technical office.

## Application of Horizontally Rotating Chains

Chains can reach a maximum rotation of 540°. For a correct usage they should be guided both internally and externally.

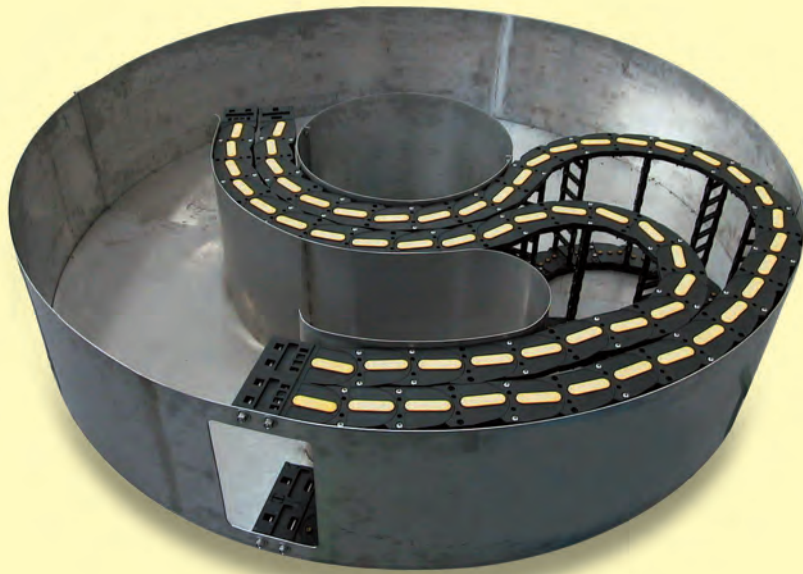

Application with 2 superimposed chains.  
Rotation 180°

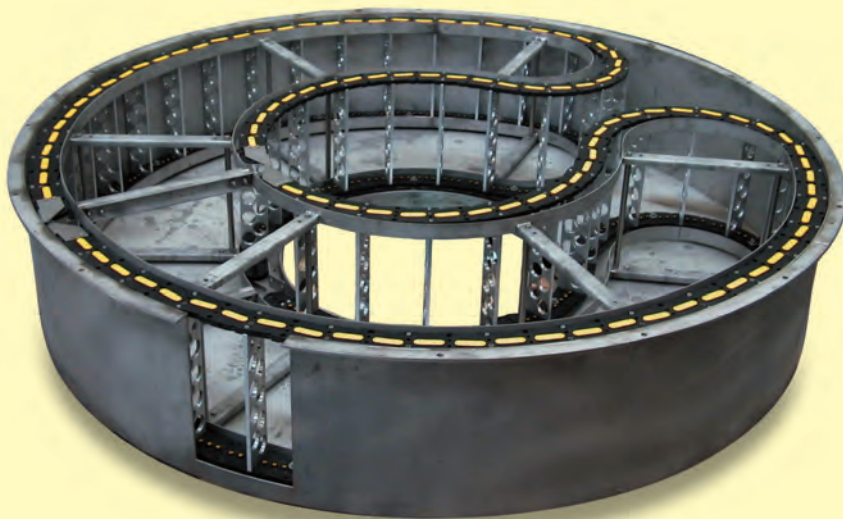

Application with 2 chains.  
Rotation 370°

## Rotation with ROBOT Type Chains

In its continuous technological evolution, Brevetti Stendalto has revolutionised since 1989 the concept of circular chains introducing the chains from the "ROBOT" series that, due to the particular construction of the links, permit them to rotate up to 540°.

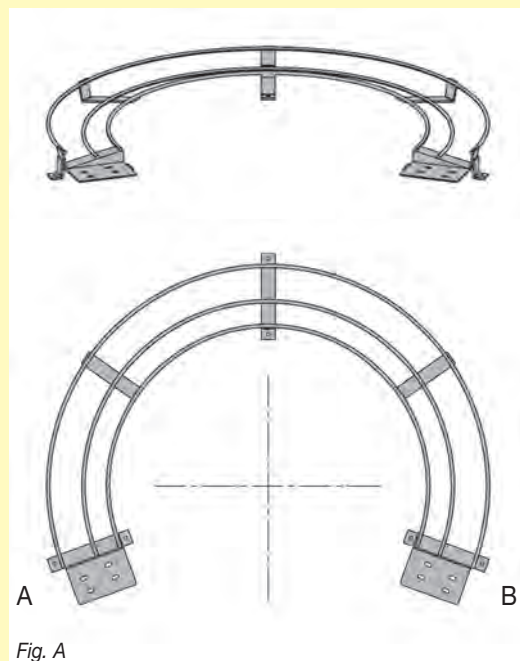
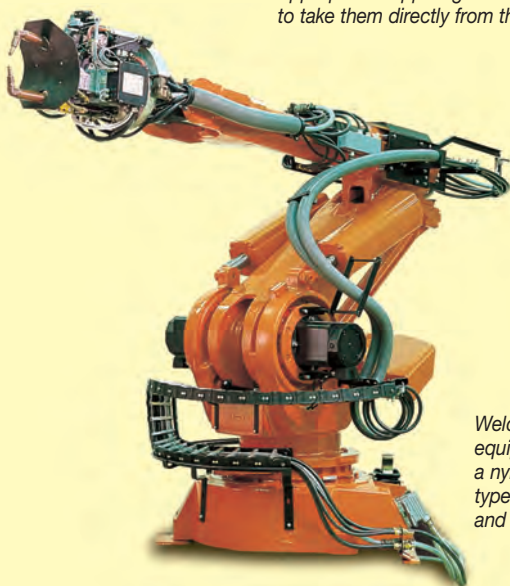

Fig. A

The stability of the chains permits rotations at higher velocities without the need for guiding supports. Only the base on which the cable leans has to have a configuration inclined to make its own travel distance easier. Appropriate support guides are available if it is not possible to take them directly from the machine.



Welding robot equipped with a nylon cable chain type 510 and guide support.

The chains from the "ROBOT" series, like all Brevetti Stendalto chains, can be modified for work in special applications.

When the use of one cable chain is not sufficient to contain all the cables/hoses it's possible to use several chains in the same application to increase the space to hold them.

## Supporting Hook

This must be selected according to the method of chain fixation.

-Left type with left fixed point chain (A)

-Right type with right fixed point chain (B)



The chains from the "ROBOT" series are self-supporting and they do not need any support up to 200°. For applications with rotations exceeding that value it is necessary to use its own appropriate accessories. To reduce the problems of taking up too much space which generally is the case with the supports, especially on robots, Brevetti Stendalto has developed a series of supports which are capable of solving the problem.



## Applications with Robot Series Chains

Using support rollers or support hooks, chains can reach a maximum rotation of 540°.

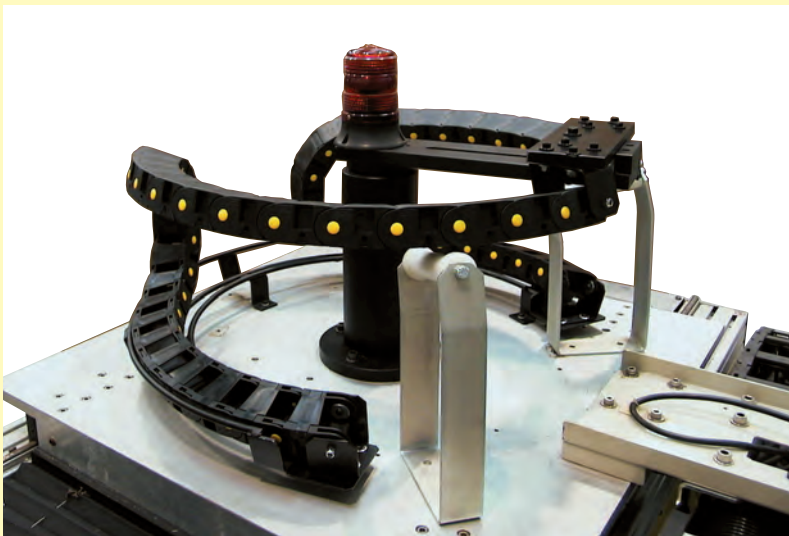

*Support rollers view.*



*Support hooks view.*

# Going Further

## Support Roller Units

For applications of cable chains with  $\frac{LS}{2}$  and weights not included in the area of the diagram of self-supporting capacity it is

necessary to use the appropriate support rollers.

To decide on the number of support rollers needed, note the following:

### One Support Roller when:

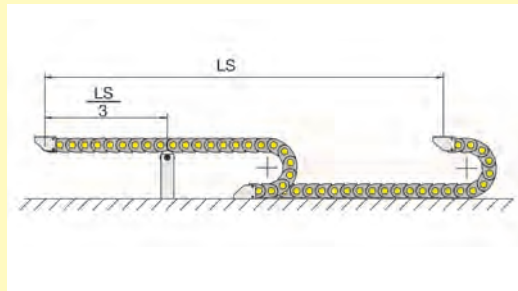

The length  $\frac{LS}{3}$  is included in the values of the diagram showing self-supporting capacity.

### Two Support Rollers when:

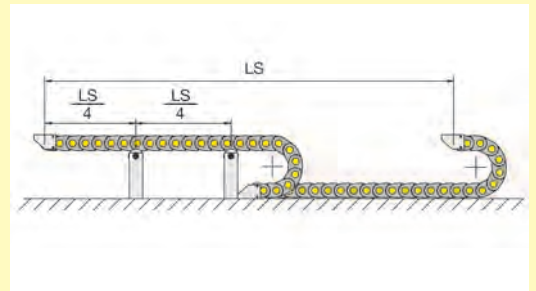

The length  $\frac{LS}{4}$  is included in the values of the diagram showing self-supporting capacity.

## Support Roller for Nylon Chains

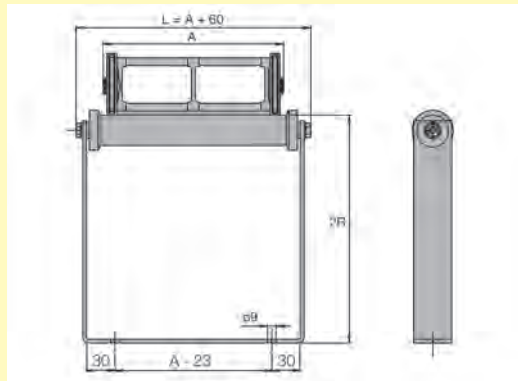

## Support Roller for Steel Chains

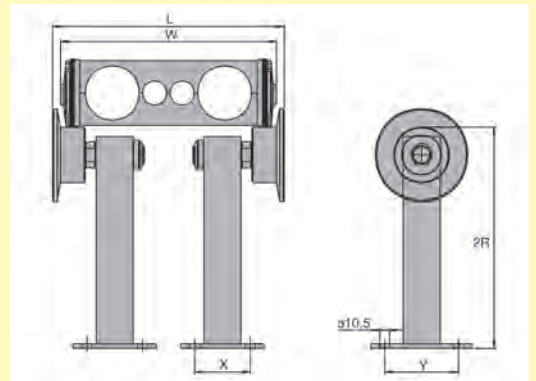

Chain Type	X	Y	L
20	70	100	W+22
30	70	100	W+22
35	70	100	W+26
40	70	100	W+26
45	130	180	W+26

### Ways of Mounting End Brackets

The end brackets make the installation of the chains possible. They are available both in nylon and in steel. The end brackets in nylon, due to their particular construction with holes for mounting on three sides, allow the chain to be installed in the four positions seen below. For the end bracket in steel instead it is necessary to specify the position of mounting. If this is not specified it will be supplied in Pos.1. Our technical office is at your disposal to solve any installation query.

Pos. 1

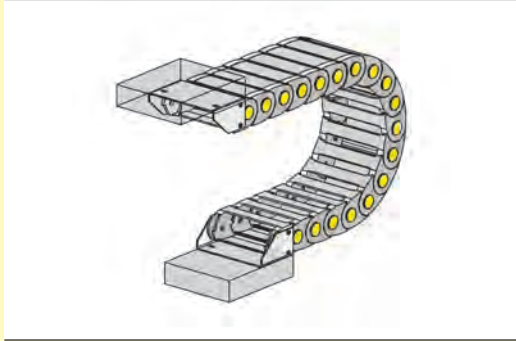

Pos. 2

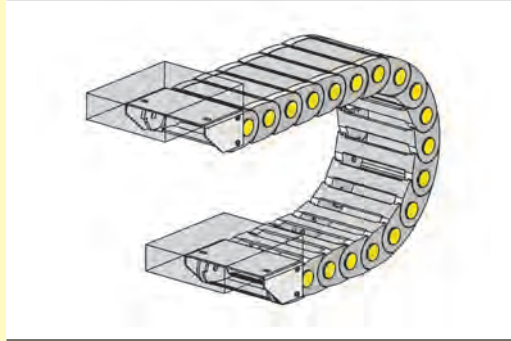

Pos. 3

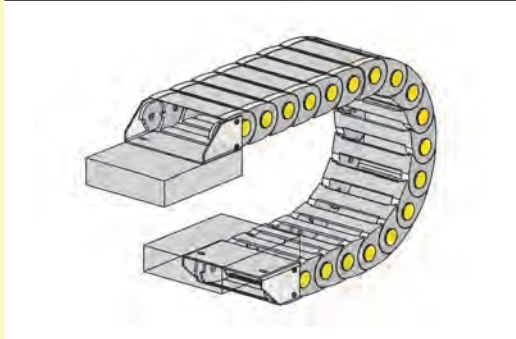

Pos. 4

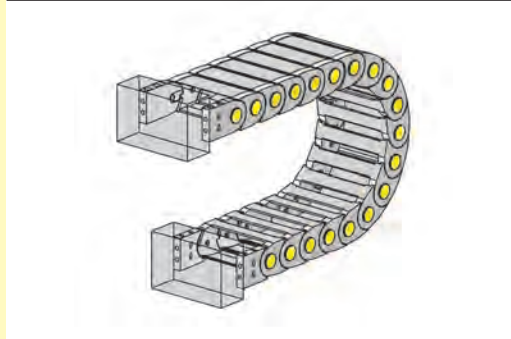

Pos. 5

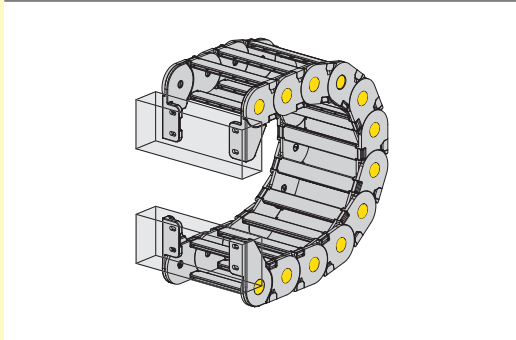

Pos. 6

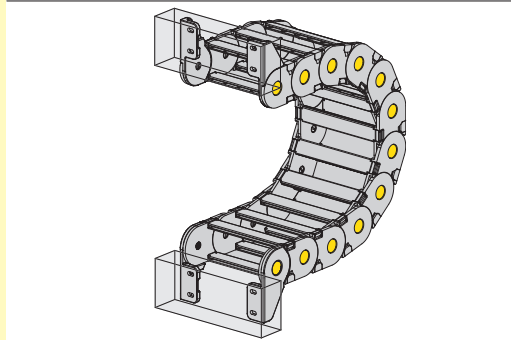



# Going Further

## Guide Channel

For a correct functioning of the cable chain it is necessary that during it's movement it lies on a flat surface. If these conditions do not exist a guide channel is necessary.

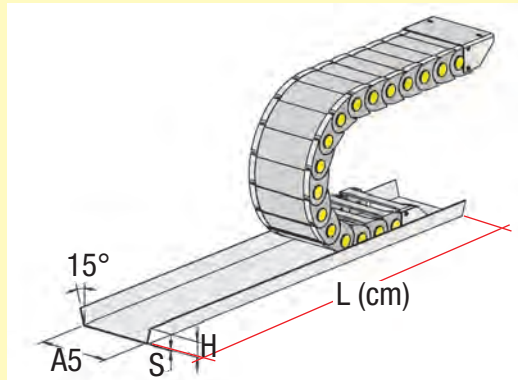

2

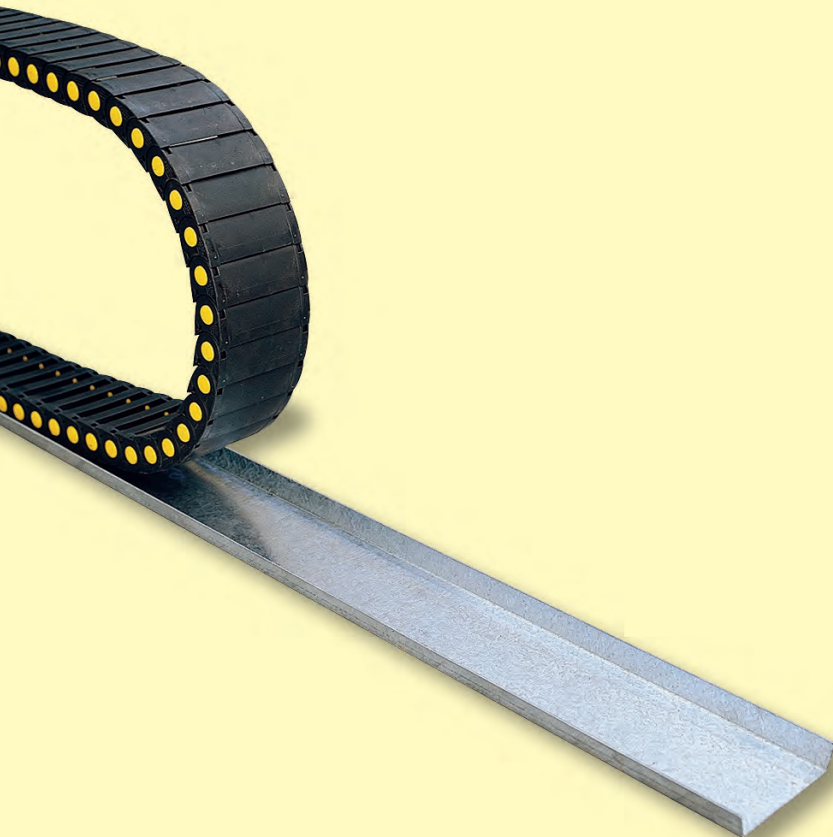

Chain type	A5 mm	H mm	S mm
200...	A+2	10	1,5
250...	A+2	10	1,5
30090-30091	A+2	15	1,5
325LI/LE...	A+2	25	1,5
325L... / 325PI...	A+2	25	1,5
335...	A+2	30	1,5
339...	A+2	30	1,5
300A...	A+2	15	1,5
300...	A+2	15	1,5
305A...	A+2	20	1,5
305...	A+2	20	1,5
355A...	A+2	25	1,5
355...	A+2	25	1,5
400...	A+2	25	1,5
435...	A+2	30	1,5
445...	A+2	30	1,5
660A...	A+2	30	1,5
770A...	A+2	30	1,5
475...	A+2	50	1,5
306...	A+2	30	1,5
307...	A+2	30	1,5
308...	A+2	40	1,5
309...	A+2	50	1,5
310T...	A+2	80	1,5
660...	A+2	30	1,5
770...	A+2	30	1,5
20...	W+2	30	1,5
30...	W+2	40	1,5
35...	W+2	50	
40...*			
45...*			

\*Seen the particular aspects of these chains we advise consultation with our technical office.

The guide channel is delivered in laminar zinc in pieces of 2000 mm. It is available on request in stainless steel.

Guide channel for chain type 355.

## Split Cross Pieces Heavy/Sliding Series

The chains from the Heavy and Sliding series are developed with two side-bands of chain connected with split cross pieces that can be

chosen between a wide number of styles to suit most various requests.

### Standard Versions:

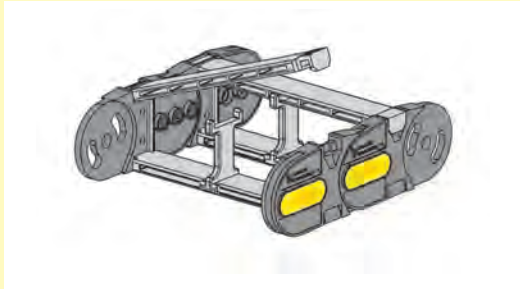

The new nylon split cross piece can open by an easy to open hinge, offering a security.

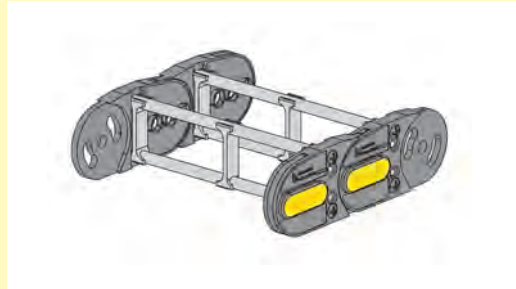

Aluminium rods screwed at the links. Maximum strength in every application. Possibilities in customising it's width. A separation of cables system.

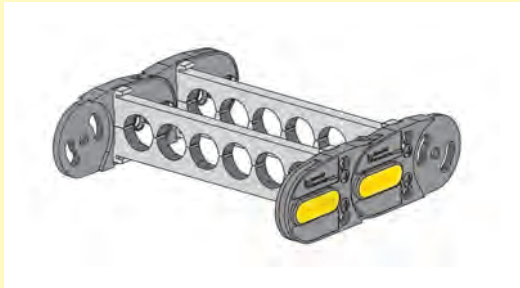

Nylon split cross pieces with holes. Many possibilities of choice between the standard models or special version on request.

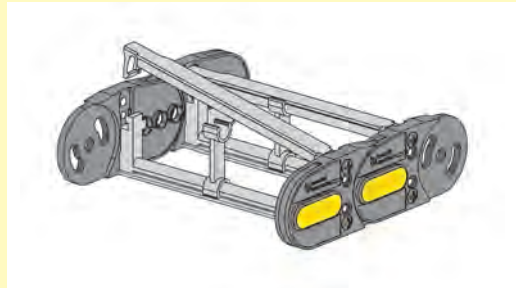

Nylon split cross pieces which open by a zip, to facilitate the operations of positioning the cables internally in the chain.

### Special Versions:



Split cross pieces made on request. The ideal solution in the case of numerous cables with limited amount of space.

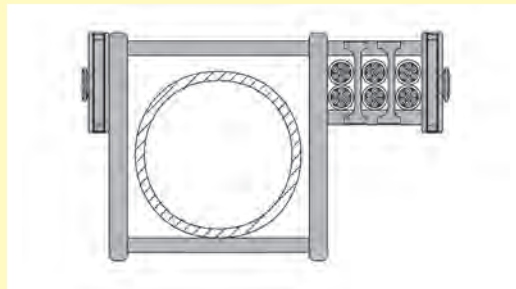

Larger split cross pieces. For the transportation of hoses of notable dimensions.

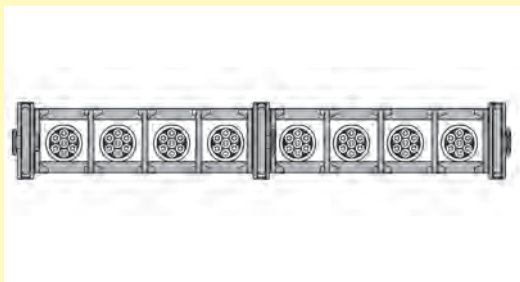

Multiple side-band chains. If it was necessary to increase the self-supporting capacity and the stability when having a large number of cables.

# Materials Used

The Brevetti Stendalto cable chains in nylon are developed with a special polyamide reinforced with glass fibre, BRYLON 6. The high resistance to tension, the low coefficient of friction together with the general characteristics of the most evolved compound thermoplastics, allow the cable chains to be used in all environments and temperatures. The main characteristics of BRYLON 6 are:

## Self-Extinguishing

Brylon 6 has the certificate UL94HB. On request the use of the polyamide V0 or V2 can be used. The resistance at eventual sparks is good.

## UV Rays

Brylon 6 is resistant to UV rays and it's therefore suitable for external applications.

## Chemical Resistance

Brylon 6 is generally resistant to oils, grease, petrol, ammonia and water (sea water). Problems could arise with the presence of acids. (See the detailed table showing resistance to various chemical agents).

## The Colouring.

The standard colouring of the Brevetti Stendalto cable chains is to have the links in black and the pins in yellow.

This combination, apart from being eye-catching represents a further security measure, the chain

## Working Temperature

Brevetti Stendalto cable chains made of polymers can be used in application with a temperature range between  $-25^{\circ}$   $+125^{\circ}$ . In case of application with "continuous" temperature lower than  $-15^{\circ}$  and higher than  $+95^{\circ}$ , the mechanical values could be reduced. In both the cases Brevetti Stendalto is able to offer solutions using special compounds; please consult us. On request it is possible to create and develop cable chains using special polyamides to be used in the following applications:

## Ex-Proof

Cable chains complying with ATEX Directive 94/9/CE. Nylon cable chains, to be used in explosion high-risk environments, can be supplied made of the special material BRYLON AD. For further information please refer to Brevetti Stendalto's Technical Office.



## Clean room-proof

To be used in clean rooms. The standard version of the cable chain 305A009 has been tested and proved to be Class 1. For further information you may require the proper documentation to our technical department.



2



Colour options.

### Links

standard colour: black  
colours by request: yellow,  
red, blue, green, grey.

### Pins

standard colour: yellow  
colours by request: black,  
red, blue, green.

700 yellow nylon chain with  
the pins in black.

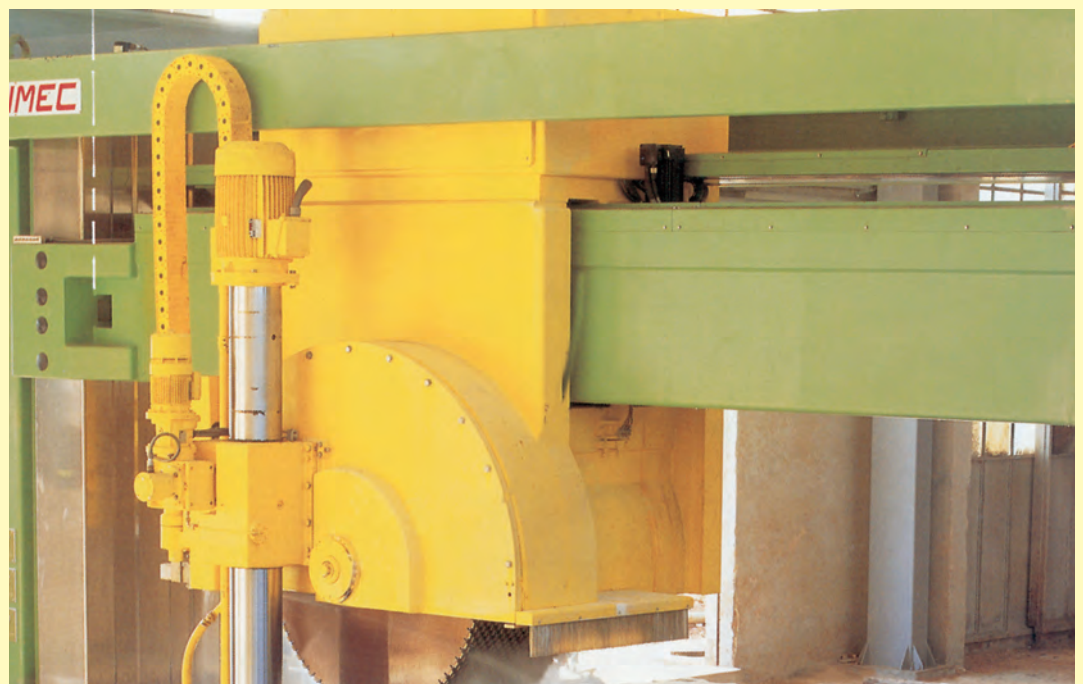



# BRYLON 6 Technical Data

Norms	Properties	Units	Typical values	
			Dry	Conditioned
<b>Thermal properties</b>				
DSC	Melting point (10° C/min.)	°C	222	
ASTM - D 696	Coefficient of linear thermal expansion	X10 <sup>-6</sup> K <sup>-1</sup>	28	
ASTM D 648	Heat distortion temperature			
ISO 75	1.82 N/mm <sup>2</sup>	°C	210	
DIN 53461	0.45 N/mm <sup>2</sup>	°C	220	
U. L. 94	Flammability		H.B.	
IEC 695-2-1	Incandescent wire Temperature	°C	650	
	Thickness	mm	3	
<b>Flammability</b>				
ASTM-D 257	Volume resistivity	Ohm cm	10 <sup>15</sup>	10 <sup>11</sup>
ASTM-D 257	Surface resistivity	Ohm	10 <sup>13</sup>	10 <sup>11</sup>
ASTM-D 149	Dielectric strength	KV/mm	22	
ASTM-D 150	Dielectric constant (10 Hz)	—	3.8	4.5
ASTM-D 150	Dissipation factor (10Hz)	—	0.02	0.09
<b>Physical properties</b>				
ASTM-D 792	Density	g/cm <sup>3</sup>	1.38	
ASTM-D 570	Water absorption at 23°C in water for 24 hours	%	0.90	
<b>Mechanical properties</b>				
ASTM-D 638	Tensile yield stress	N/mm <sup>2</sup>	195	115
ISO R/527				
DIN 53455	Ultimate elongation	%	2.6	4
ASTM-D 638				
ISO R/527	Tensile modulus of elasticity	N/mm <sup>2</sup>	10600	6900
DIN 53457				
ASTM-D 790				
ISO 178	Flexural strength	N/mm <sup>2</sup>	310	190
DIN 53452				
ASTM-D 790	Flexural modulus	N/mm <sup>2</sup>	10500	6800
ISO 178				
ASTM-D 256	Unnotched Izod impact strength	J/m	140	300
ISO 180/4C	Notched Izod impact strength	KJ/m <sup>2</sup>	110	125
ASTM-D 785	Rockwell hardness	Scala R	122	114

**Dry**  
H<sub>2</sub>O < 0,15%

**Conditioned**  
equilibrium moisture content at 23° - 50% R.H.



## Chemical Resistance

Chemical agents	BRYLON 6			STEEL	
	Concentration %	Amorphous	Crystal	Concentration %	
Methyl acetate	100	RB3	RB2	100	RB
Acetone	100	RB4	RB	100	RB
Acetic acid (aqueous solution)	40	AF	AF	40	AF
Acetic acid (aqueous solution)	10	AF	AF	10	AF
Acetic acid		AF	AF		AF
Citric acid	10	AD 15	RD	10	AD
Hydrochloric acid (aqueous solution)	36	S	S	36	S
Hydrochloric acid (aqueous solution)	10	AF	AF	10	S
Hydrochloric acid (aqueous solution)	2	AF	AD	2	S
Chromic acid (aqueous solution)	10	AF	AF	10	AF
Chromic acid (aqueous solution)	1	RD	RD	1	AF
Hydrofluoric acid	40	AF	AF	40	S
Formic acid (aqueous solution)	85 S	S		85 S	AD
Formic acid (aqueous solution)	40 S	AF	AF	40 S	AD
Phosphoric acid (aqueous solution)	10	AF	AF	10	S
Oleic acid	100	RB3	RB3	100	RD
Sulphuric acid	98	S	S	98	S
Sulphuric acid (aqueous solution)	40	AF	AF	40	S
Sulphuric acid (aqueous solution)	10	AF	AF	10	S
Sulphuric acid (aqueous solution)	2	AF	AD	2	S
Tartaric acid (aqueous solution)		RD	RB		RD
Water		RB10	RB9		RD
Chlorine water		RD	RD		AD
Ethyl alcohol	96	RD17	RB3	96	RB
Ammonia	10	RB11	RB	10	AF
Petrol	100	RB1	RB	100	RB
Bitumen		RD	RD		RB
Potassium carbonate	100	RB	RB	100	AF
Sodium carbonate	10	RB10	RB3	10	AF
Ammonium chloride (aqueous solution)	10	RB	RB	10	AF
Calcium chloride (aqueous solution)	20	S	S	20	AF
Calcium chloride (aqueous solution)	10	RB	RB	10	AF
Sodium chloride	10	RB	RB	10	AF
Formaldehyde (aqueous solution)	30	RD	RB	30	AD
Fat		RB	RB		RB
Milk		RB	RB		RB
Mercury		RB	RB		RB
Oils		RB	RB		RB
Oil		RB	RB		RB
Paraffin oil		RB	RB		RB
Silicon oil		RB	RB		RB
Diesel oil		RB	RB		RB
Mineral oil		RB	RB		RB
Ozone		AF	AF		AF
Oil		RB	RB		RB
Potassium hydroxide (aqueous solution)	10	RB9	RB3	10	S
Sodium hydroxide (aqueous solution)	50	RD	RD	50	S
Sodium hydroxide (aqueous solution)	10	RB5	RB	10	S
Sodium hydroxide (aqueous solution)	5	RB9	RB	5	S
Aluminium sulphate	10	RB	RB	10	AF
Soap (aqueous solution)		RB	RB		RB
Tincture of iodine		AF	AF		AD
Trichloroethylene		RD5	RD4		RB
Vaseline		RB	RB		RB

The table shows the resistance to chemical agents of BRYLON 6 and Steel.

**RB**  
Very good resistance.

**RD**  
Good resistance.

**AD**  
Limited resistance.

**AF**  
Poor resistance.

**S**  
Soluble.

**Amorphous**  
Polymer in amorphous state.

**Crystal**  
Polymer in crystalline state.

The number by resistance value side shows which is the % weight increase due to swelling.

All data contained in this publication are laboratory and design values, to be verified in practical applications.