

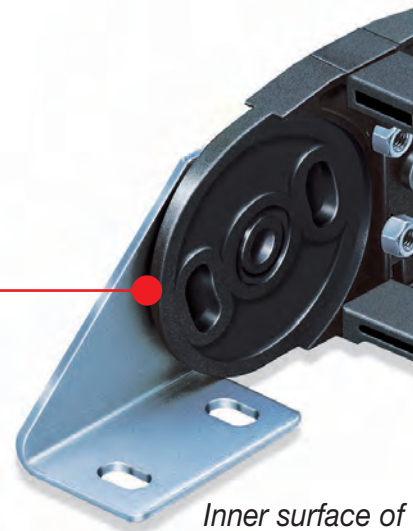

Nylon Cable Chains Heavy Series

H45SC Series	page 90
H57SC Series	page 92
H80SC/SA Series	page 94
H110SC/SA Series	page 96
H110T Series	page 98
306SU Series	page 100
306B Series	page 102
307SU Series	page 104
307B Series	page 106
307E Series	page 108
308SU Series	page 110
308B Series	page 112
308E Series	page 114
309SU Series	page 116
309B Series	page 118
<hr/>	
Horizontal Separation	page 212

Steel or nylon end brackets



*Inner surface of
completely smooth*

Wide range of cross pieces
available in the following types:
Open and close, with a
"Snap-Fit" action
Aluminium Rods
With Pre-Drilled Holes

Nylon separator. Cables can be laid
apart from each other

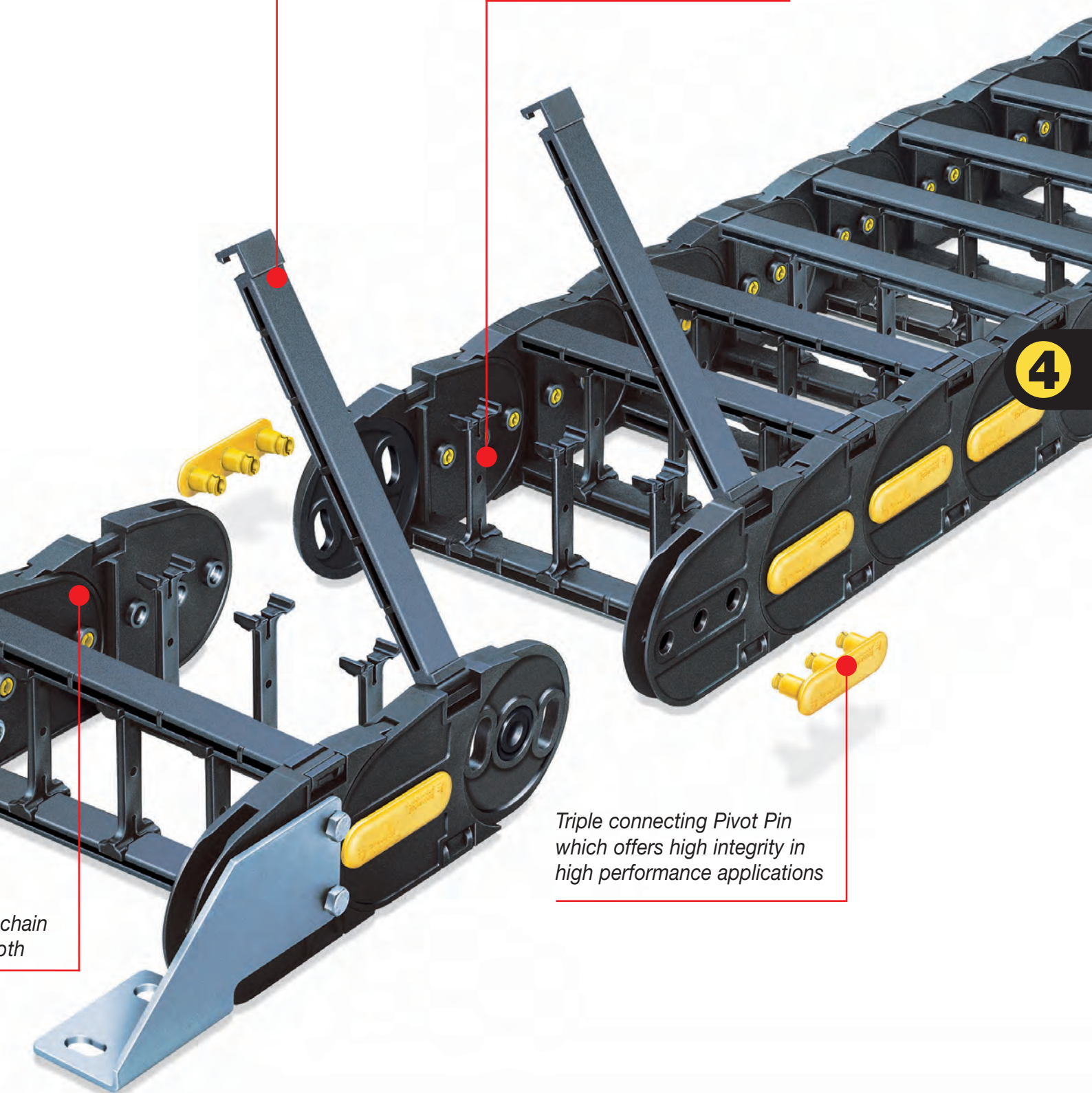

chain
both

Triple connecting Pivot Pin
which offers high integrity in
high performance applications

Serie Heavy

H45SC

Nylon cable chain with opening frames

Inner height (D) 45 mm

Sideband construction with quickly removable pin. Frames openable from either side on both inner and outer radius. As standard the chain comes with frames every second link, on request with frames every link. Vertical and horizontal modular separator system is available.

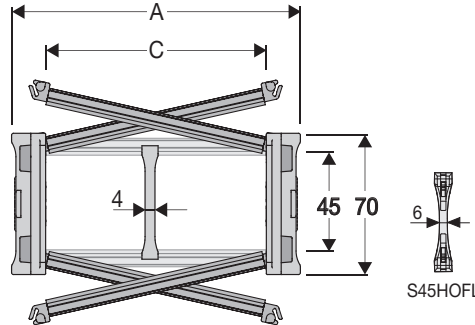

Separator

- Unassembled	Part.no S45CF3
- Assembled*	Part.no S45CF3MCI
- Assembled**	Part.no S45CF3MCE

Strong-hold Separator

for C > 250 mm

- Unassembled	Part.no S45HOFL
- Assembled	Part.no S45HOFL

Pin

Part.no PNH45RS

* for chain opening outer radius

** for chain opening inner radius

Technical Characteristics when self-supporting

Speed	8 m/s
Acceleration	40 m/s ²

For higher requirements please consult our technical dept.

4

For sliding applications, characteristics techniques may vary depending on the frequency, added weight and work environment.

A	B	C	D	R	Weight/m	Chain
mm	mm	mm	mm	mm	kg	Part Number
113	70	75	45	075-100-125-150-175-200-250-300	2,29	H45SC075 □□□ *
138	70	100	45	075-100-125-150-175-200-250-300	2,37	H45SC100 □□□ *
163	70	125	45	075-100-125-150-175-200-250-300	2,44	H45SC125 □□□ *
188	70	150	45	075-100-125-150-175-200-250-300	2,52	H45SC150 □□□ *
213	70	175	45	075-100-125-150-175-200-250-300	2,60	H45SC175 □□□ *
238	70	200	45	075-100-125-150-175-200-250-300	2,67	H45SC200 □□□ *
263	70	225	45	075-100-125-150-175-200-250-300	2,75	H45SC225 □□□ *
288	70	250	45	075-100-125-150-175-200-250-300	2,83	H45SC250 □□□ *
313	70	275	45	075-100-125-150-175-200-250-300	2,91	H45SC275 □□□ *
338	70	300	45	075-100-125-150-175-200-250-300	2,99	H45SC300 □□□ *
388	70	350	45	075-100-125-150-175-200-250-300	3,14	H45SC350 □□□ *
438	70	400	45	075-100-125-150-175-200-250-300	3,30	H45SC400 □□□ *

*Complete the code by inserting the value of the radius (R): Ex. H45SC100 □ □ □ □

Chain equipped with nylon frame every pitch: complete the code by inserting the letter D. Ex. H45SC100250 □

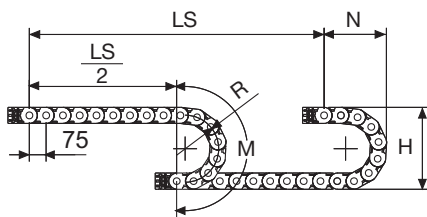

Length of chain (L)

Half travel distance ($\frac{LS}{2}$)

plus length of curve (M) or (M1)

$$L = \frac{LS}{2} + M \text{ or } M1$$

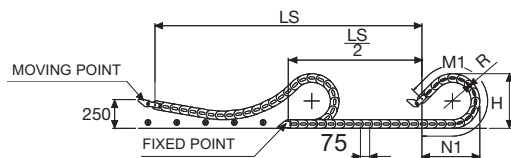

R	H	N	M	N1	M1
mm	mm	mm	mm	mm	mm
075	220	185	390	265	540
100	270	210	465	275	595
125	320	235	545	395	870
150	370	260	625	515	1150
175	420	285	700	635	1430
200	470	310	780	750	1705
250	570	360	940	990	2265
300	670	410	1095	1225	2820



Self-Supporting Capacity Diagram

The maximum length of the self-supporting capacity or in admissible sagging in relationship to the weight of the cables and hoses contained per linear metre.

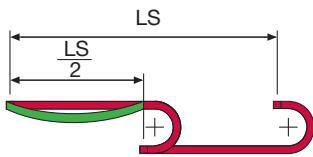
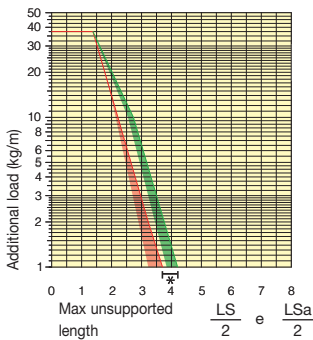

***If the chain is in the ADMISSIBLE SAGGING area (between GREEN and RED area) version with frames on every link is necessary.**

The area in the diagram considers the difference of weight between various widths.

Red for self-supporting chain, green for chain in admissible sagging.

For applications with ($\frac{LS}{2}$) and weights not included in the diagram of self-supporting capacity, verify the possible use of support rollers (see page 30).

End Brackets

The end brackets set allows the two ends of the chain to be attached to the equipment. Set complete with tie-wrap clamps available on request.

Nylon Type

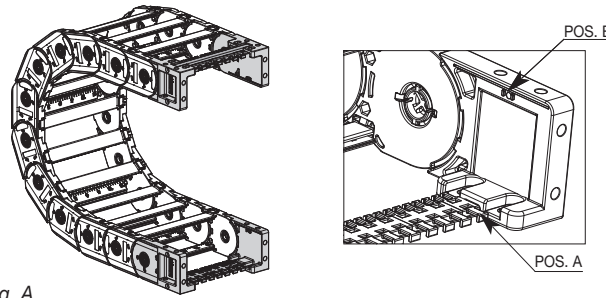
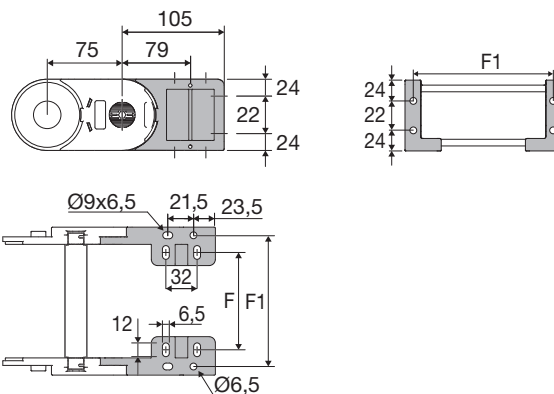

Fig. A
The chain can be fixed frontally, inner and outer radius (Fig A)



Chain Type	F mm
H45SC075	91
H45SC100	116
H45SC125	141
H45SC150	166
H45SC175	191
H45SC200	216
H45SC225	241
H45SC250	266
H45SC275	291
H45SC300	316
H45SC350	366
H45SC400	416

Nylon Type Part Numbers

Complete Set Assembled Chain Type	End Brackets set
H45SC... ANH45SC□□□KM□**	
Complete Set Unassembled Chain Type	End Brackets set
H45SC... ANH45SC□□□K	

** 1=Pos.1; 2=Pos.2; 3=Pos.3

Chain Type	F mm
H45SC075	55,5
H45SC100	80,5
H45SC125	105,5
H45SC150	130,5
H45SC175	155,5
H45SC200	180,5
H45SC225	205,5
H45SC250	230,5
H45SC275	255,5
H45SC300	280,5
H45SC350	330,5
H45SC400	380,5

Tiewrap Clamp

Complete Set Assembled Chain Type	Tiewrap Clamp set
Pos. A	SFCTH45□□□*KMA
Pos. B	SFCTH45□□□*KM
Complete Set Unassembled Mounting Position	Tiewrap Clamp set
Pos. A	SFCTH45□□□*KA
Pos. B	SFCTH45□□□*K

* Inner Width C

Serie Heavy

H45SC

Nylon cable chain with opening frames

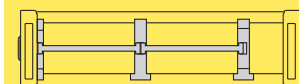

Separation System page 216



How to open the frame



How to release the pin junction

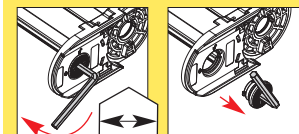

8 mm



Suitable to long travel distance in frame every pitch version. To choose the guide channel see page 182

For further informations please consult Brevetti Stendalto's Technical Office

Serie Heavy

H57SC

Nylon cable chain with opening frames

Inner height (D) 57 mm

Sideband construction with quickly removable pin. Frames openable from either side on both inner and outer radius. As standard the chain comes with frames every second link, on request with frames every link. Vertical and horizontal modular separator system is available.

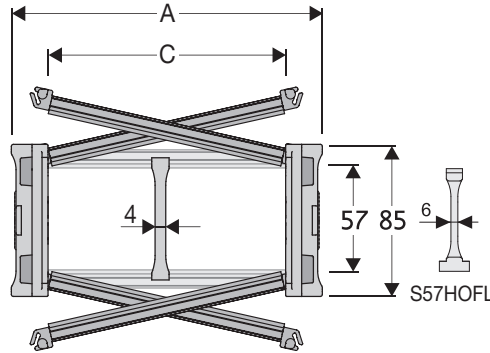

Separator	
- Unassembled	Part.no S57CF3
- Assembled*	Part.no S57CF3MCI
- Assembled**	Part.no S57CF3MCE
Strong-hold Separator	
for C > 250 mm	
- Unassembled	Part.no S57HOFL
- Assembled	Part.no S57HOFL
Pin	
Part.no PNH57RS	

* for chain opening outer radius
** for chain opening inner radius

Technical Characteristics when self-supporting

Speed	8 m/s
Acceleration	40 m/s ²

For higher requirements please consult our technical dept.

4

For sliding applications, characteristics techniques may vary depending on the frequency, added weight and work environment.

A	B	C	D	R	Weight/m	Chain
mm	mm	mm	mm	mm	kg	Part Number
113	85	75	57	150-180-200-250-300-350-400	3,03	H57SC075 □□□ *
138	85	100	57	150-180-200-250-300-350-400	3,09	H57SC100 □□□ *
163	85	125	57	150-180-200-250-300-350-400	3,16	H57SC125 □□□ *
188	85	150	57	150-180-200-250-300-350-400	3,22	H57SC150 □□□ *
213	85	175	57	150-180-200-250-300-350-400	3,29	H57SC175 □□□ *
238	85	200	57	150-180-200-250-300-350-400	3,35	H57SC200 □□□ *
263	85	225	57	150-180-200-250-300-350-400	3,42	H57SC225 □□□ *
288	85	250	57	150-180-200-250-300-350-400	3,48	H57SC250 □□□ *
313	85	275	57	150-180-200-250-300-350-400	3,55	H57SC275 □□□ *
338	85	300	57	150-180-200-250-300-350-400	3,61	H57SC300 □□□ *
388	85	350	57	150-180-200-250-300-350-400	3,74	H57SC350 □□□ *
438	85	400	57	150-180-200-250-300-350-400	3,88	H57SC400 □□□ *

*Complete the code by inserting the value of the radius (R): Ex. H57SC100 □ □ □ □

Chain equipped with nylon frame every pitch: complete the code by inserting the letter D. Ex. H57SC100250 □

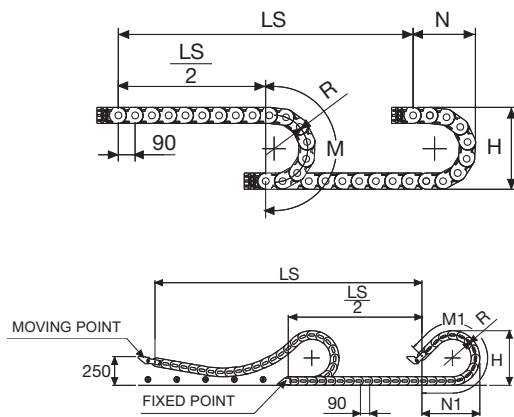

Length of chain (L)

Half travel distance ($\frac{LS}{2}$)
plus length of curve (M) or (M1)

$$L = \frac{LS}{2} + M \text{ or } M1$$

R	H	N	M	N1	M1
mm	mm	mm	mm	mm	mm
150	385	283	655	565	1235
180	445	313	750	705	1570
200	485	333	810	805	1605
250	585	383	970	1040	2350
300	685	433	1125	1275	2905
350	785	483	1280	1510	3460
400	885	533	1440	1750	4020



Version with frames mounted on every pitch

Self-Supporting Capacity Diagram

The maximum length of the self-supporting capacity or in admissible sagging ($\frac{LS}{2}$) in relationship to the weight of the cables and hoses contained per linear metre.

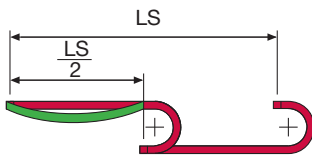
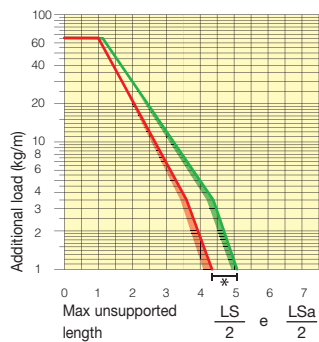

***If the chain is in the ADMISSIBLE SAGGING area (between GREEN and RED area) version with frames on every link is necessary.**

The area in the diagram considers the difference of weight between various widths of chain with nylon frame every second link.

Red for self-supporting chain, green for chain in admissible sagging.

For applications with ($\frac{LS}{2}$) and weights not included in the diagram of self-supporting capacity, verify the possible use of support rollers (see page 30).

End Brackets

The end brackets set allows the two ends of the chain to be attached to the equipment. Set complete with tie-wrap clamps available on request.

Nylon Type

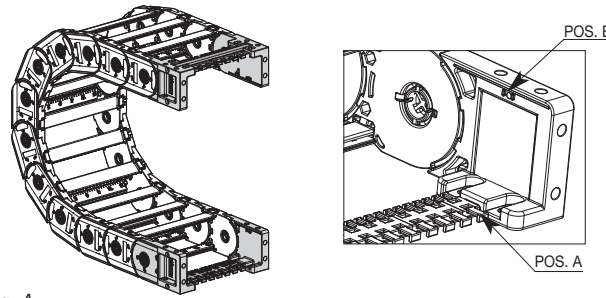
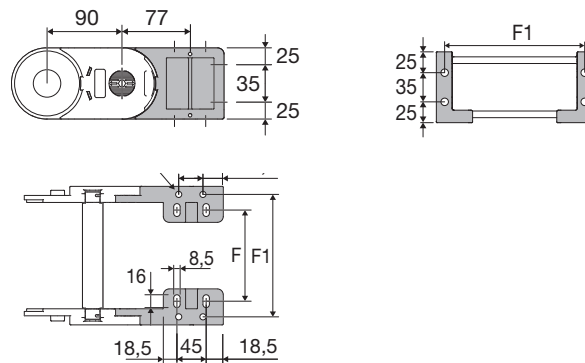

Fig. A
The chain can be fixed frontally, inner and outer radius (Fig A)



Chain Type	F mm
H57SC075	51
H57SC100	76
H57SC125	101
H57SC150	126
H57SC175	151
H57SC200	176
H57SC225	201
H57SC250	226
H57SC275	251
H57SC300	276
H57SC350	326
H57SC400	376

Nylon Type Part Numbers

Complete Set Assembled Chain Type	End Brackets set
H57SC...	ANH57KM□**
Complete Set Unassembled Chain Type	End Brackets set
H57SC...	ANH57K

** 1=Pos.1; 2=Pos.2; 3=Pos.3

Chain Type	F1 mm
H57SC075	98
H57SC100	123
H57SC125	148
H57SC150	173
H57SC175	198
H57SC200	223
H57SC225	248
H57SC250	273
H57SC275	298
H57SC300	323
H57SC350	373
H57SC400	423

Tiewrap Clamp

Complete Set Assembled Chain Type	Tiewrap Clamp set
Pos. A	SFCTH57□□□*KMA
Pos. B	SFCTH57□□□*KM
Complete Set Unassembled Mounting Position	Tiewrap Clamp set
Pos. A	SFCTH57□□□*KA
Pos. B	SFCTH57□□□*K

* Inner Width C

Serie Heavy

H57SC

Nylon cable chain with opening frames



H57B

On request can be supplied with rods made of stainless steel or bright zinc plated steel.



H57T

On request can be supplied with drawn made of stainless steel or bright zinc plated steel.

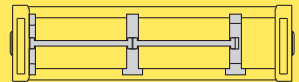

Separation System page 216

How to open the frame



How to release the pin junction

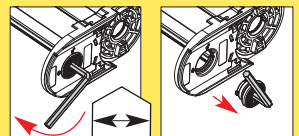

8 mm



Suitable to long travel distance in frame every pitch version. See page 182

For further informations please consult Brevetti Stendalto's Technical Office

Serie Heavy

H80SC Nylon Chain with opening frame with a snap

Inner height (D) 80,5 mm

Sideband construction with quickly removable pin. Frames openable from either side on both inner and outer radius. As standard the chain comes with frames every link.

Vertical and horizontal modular separator system is available.

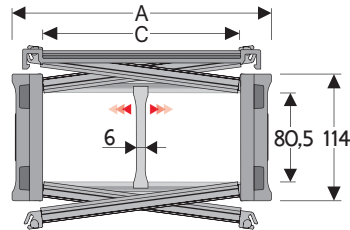

Separator

- Unassembled	Part.no SH80SCF6
- Assembled*	Part.no SH80SCF6MCI
- Assembled**	Part.no SH80SCF6MCE

Strong-hold Separator

for C > 250 mm

- Unassembled	Part.no SH80HOF6L
- Assembled	Part.no SH80HOF6LMC

* for chain opening outer radius

** for chain opening inner radius

Technical characteristics when self-supported

Speed	8 m/s
Acceleration	40 m/s ²

For higher requirements please consult our technical dept.

4

For sliding applications, characteristics techniques may vary depending on the frequency, added weight and work environment.

R	H	N	M	N1	M1
mm	mm	mm	mm	mm	mm
200	514	377	870	810	1775
250	614	427	1030	1050	2330
300	714	477	1185	1285	2885
350	814	527	1340	1525	3445
400	914	577	1500	1760	4000
500	1114	677	1815	2235	5115
600	1314	777	2125	2705	6225

A	B	C	D	R	Weight/m	Chain
mm	mm	mm	mm	mm	kg	Part Number
205	114	150	80,5	200-250-300-350-400-500-600	6,70	H80SC150 □□□*
230	114	175	80,5	200-250-300-350-400-500-600	6,87	H80SC175 □□□*
255	114	200	80,5	200-250-300-350-400-500-600	7,04	H80SC200 □□□*
280	114	225	80,5	200-250-300-350-400-500-600	7,20	H80SC225 □□□*
305	114	250	80,5	200-250-300-350-400-500-600	7,37	H80SC250 □□□*
330	114	275	80,5	200-250-300-350-400-500-600	7,52	H80SC275 □□□*
355	114	300	80,5	200-250-300-350-400-500-600	7,66	H80SC300 □□□*
380	114	325	80,5	200-250-300-350-400-500-600	7,86	H80SC325 □□□*
405	114	350	80,5	200-250-300-350-400-500-600	8,05	H80SC350 □□□*
430	114	375	80,5	200-250-300-350-400-500-600	8,23	H80SC375 □□□*
485	114	430	80,5	200-250-300-350-400-500-600	8,62	H80SC430 □□□*
555	114	500	80,5	200-250-300-350-400-500-600	9,14	H80SC500 □□□*

*Complete the code by inserting the value of the radius (R): Ex. H80SC200 □ □ □ □

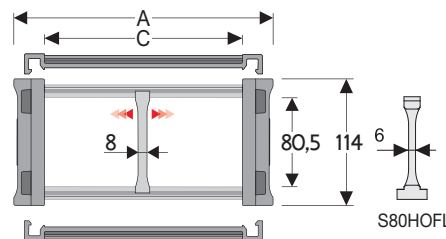

Separator

- Unassembled	Part.no S80
- Assembled*	Part.no S80MCI
- Assembled**	Part.no S80MCE

Strong-hold Separator

for C > 250 mm

- Unassembled	Part.no S80HOF6L
- Assembled	Part.no S80HOF6LMC

Pin

Part.no PNH80RS

* for chain opening outer radius

** for chain opening inner radius

H80SA

Version with openable frame by both sides

A	B	C	D	R	Weight/m	Chain
mm	mm	mm	mm	mm	kg	Part Number
129	114	74	80,5	200-250-300-350-400-500-600	5,99	H80SA074 □□□*
149	114	94	80,5	200-250-300-350-400-500-600	6,10	H80SA094 □□□*
174	114	119	80,5	200-250-300-350-400-500-600	6,22	H80SA119 □□□*
181	114	126	80,5	200-250-300-350-400-500-600	6,23	H80SA126 □□□*

*Complete the code by inserting the value of the radius (R): Ex. H80SA119 □ □ □ □

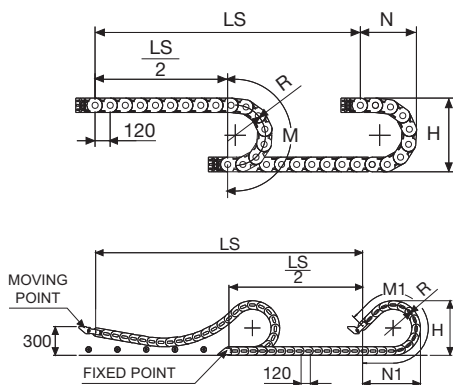

Version with frames mounted on every pitch

Self-Supporting Capacity Diagram

The maximum length of the self-supporting capacity or in admissible sagging ($\frac{LS}{2}$) in relationship to the weight of the cables and hoses contained per linear metre.

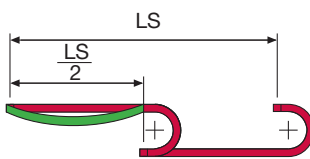
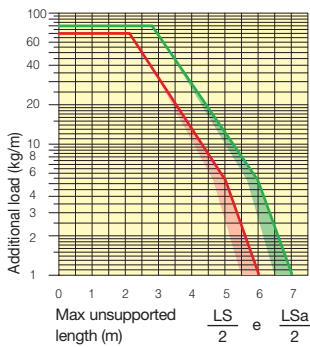

The area in the diagram considers the difference of weight between various widths of chain with nylon frame every second link.

Red for self-supporting chain, green for chain in admissible sagging.

For applications with ($\frac{LS}{2}$) and weights not included in the diagram of self-supporting capacity, verify the possible use of support rollers (see page 30).

End Brackets

The end brackets set allows the two ends of the chain to be attached to the equipment. Set complete with tie-wrap clamps available on request.

Nylon Type

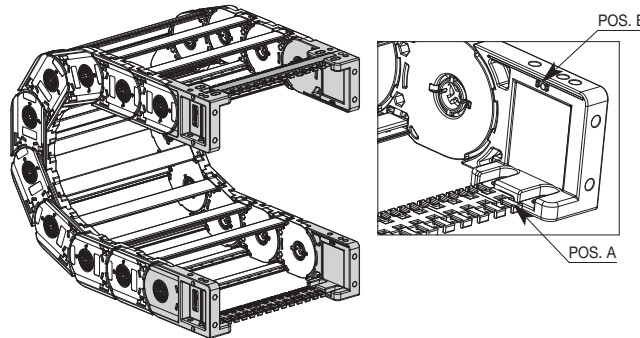
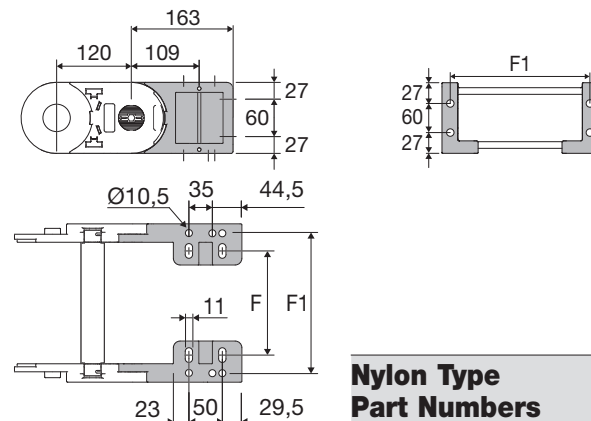

Fig. A
The chain can be fixed frontally, inner and outer radius (Fig A)



Chain Type	F mm	F1 mm
H80SC150	124	177,5
H80SC175	149	202,5
H80SC200	174	227,5
H80SC225	199	252,5
H80SC250	224	277,5
H80SC275	249	302,5
H80SC300	274	327,5
H80SC325	299	352,5
H80SC350	324	377,5
H80SC375	349	402,5
H80SC430	404	457,5
H80SC500	474	527,5
H80SA074	48	101,5
H80SA094	68	121,5
H80SA119	93	146,5
H80SA126	100	153,5

Length of chain (L)

Half travel distance ($\frac{LS}{2}$)

plus length of curve (M) or (M1)

$$L = \frac{LS}{2} + M \text{ or } M1$$

Nylon Type Part Numbers

Assembled Chain Type	End Brackets set
H80SC	ANH80KM□**

Unassembled Chain Type	End Brackets set
H80SC	ANH80K*

Tiewrap Clamp

Complete Set Assembled Mounting Position	Tiewrap Clamp set
Pos. A	SFCTH80□□□*KMA
Pos. B	SFCTH80□□□*KM

Complete Set Unassembled Mounting Position	Tiewrap Clamp set
Pos. A	SFCTH80□□□*KA
Pos. B	SFCTH80□□□*K

* Inner Width C

** 1=Pos.1; 2=Pos.2; 3=Pos.3

*** For 074 and 094 shares assembly is only on position B

Serie Heavy

H80SC

Nylon chain with opening frame with a snap



H80B

On request can be supplied with rods made of stainless steel or aluminium.



H80T

On request can be supplied with drawn made of aluminium.

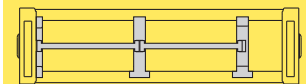

Separation System page 216

How to open the frame



How to release the pin junction

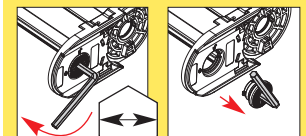

10 mm



Suitable to long travel distance in frame every pitch version. See page 184

For further informations please consult Brevetti Stendalto's Technical Office

Serie Heavy

H110SC

Nylon Chain with opening frame with a snap

Inner height (D) 115 mm

Sideband construction with quickly removable pin. Frames openable from either side on both inner and outer radius. As standard the chain comes with frames every link.

Vertical and horizontal modular separator system is available.

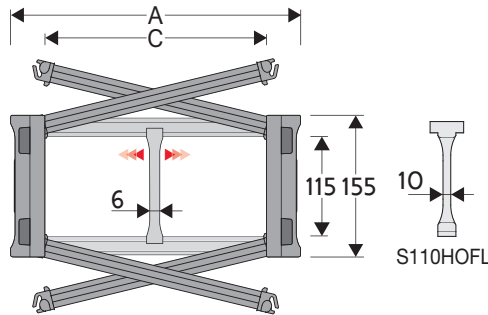

Separator

- Unassembled	Part.no S110F3
- Assembled*	Part.no S110F3MCI
- Assembled**	Part.no S110F3MCE

Strong - Hold Separator for C > 250 mm

- Unassembled	Part.no S110HOFL
- Assembled	Part.no S110HOFLMC

Pin

Part.no PNH110RS

* for chain opening outer radius

** for chain opening inner radius

Technical characteristics when self-supported

Speed	8 m/s
Acceleration	40 m/s ²

For higher requirements please consult our technical dept.

4

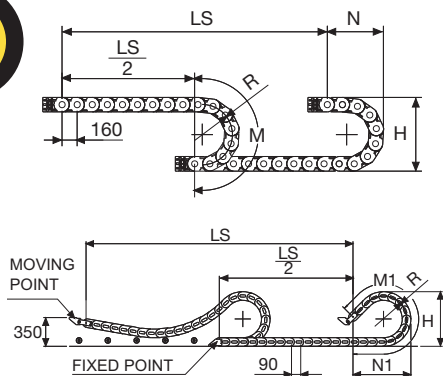

A	B	C	D	R	Weight/m	Chain
mm	mm	mm	mm	mm	kg	Part Number
205	155	150	115	200-250-300-400-500-600-700-750	8,66	110SC150 □□□*
230	155	175	115	200-250-300-400-500-600-700-750	8,79	110SC175 □□□*
255	155	200	115	200-250-300-400-500-600-700-750	8,91	110SC200 □□□*
280	155	225	115	200-250-300-400-500-600-700-750	9,03	110SC225 □□□*
305	155	250	115	200-250-300-400-500-600-700-750	9,16	110SC250 □□□*
330	155	275	115	200-250-300-400-500-600-700-750	9,27	110SC275 □□□*
355	155	300	115	200-250-300-400-500-600-700-750	9,38	110SC300 □□□*
380	155	325	115	200-250-300-400-500-600-700-750	9,53	110SC325 □□□*
405	155	350	115	200-250-300-400-500-600-700-750	9,70	110SC350 □□□*
430	155	375	115	200-250-300-400-500-600-700-750	9,80	110SC375 □□□*
485	155	430	115	200-250-300-400-500-600-700-750	10,10	110SC430 □□□*
555	155	500	115	200-250-300-400-500-600-700-750	10,48	110SC500 □□□*

*Complete the code by inserting the value of the radius (R): Ex. 110SC350 □ □ □ □

For sliding applications, characteristics techniques may vary depending on the frequency, added weight and work environment.

R	H	N	M	N1	M1
mm	mm	mm	mm	mm	mm
200	557	418	950	855	1820
250	657	468	1110	1095	2375
300	757	518	1265	1335	2935
400	957	618	1580	1805	4045
500	1157	718	1895	2280	5160
600	1357	818	2205	2750	6270
700	1557	918	2520	3225	7385
750	1657	968	2680	3460	7940



Self-Supporting Capacity Diagram

The maximum length of the self-supporting capacity or in admissible sagging ($\frac{LS}{2}$) in relationship to the weight of the cables and hoses contained per linear metre.

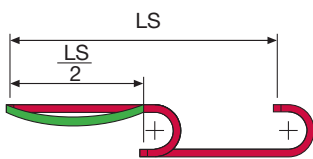
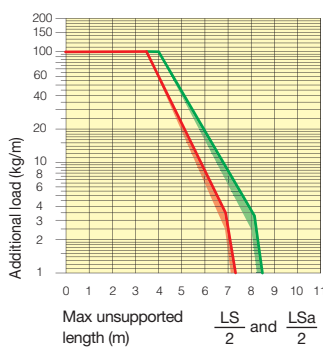

The area in the diagram considers the difference of weight between various widths of chain with nylon frame every second link.

Red for self-supporting chain, green for chain in admissible sagging.

For applications with ($\frac{LS}{2}$) and weights not included in the diagram of self-supporting capacity, verify the possible use of support rollers (see page 30).

Length of chain (L)
Half travel distance ($\frac{LS}{2}$)
plus length of curve (M) or (M1)

$$L = \frac{LS}{2} + M \text{ or } M1$$

Bright Zinc Plated Steel End Brackets

The end brackets set allows the two ends of the chain to be attached to the equipment. Set complete with tie-wrap clamps available on request.

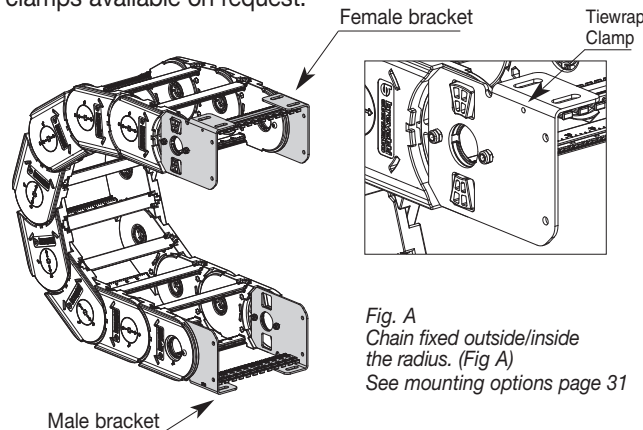
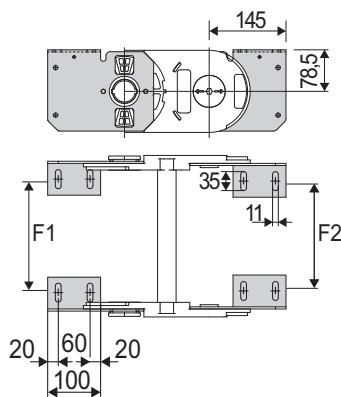

Fig. A
Chain fixed outside/inside the radius. (Fig A)
See mounting options page 31



Chain Type	F1 mm
110SC150	120
110SC175	145
110SC200	170
110SC225	195
110SC250	220
110SC275	245
110SC300	270
110SC325	295
110SC350	320
110SC375	344
110SC430	400
110SC500	470
Special widths	F= C-85

Chain Type	F2 mm
110SC150	112
110SC175	137
110SC200	162
110SC225	187
110SC250	212
110SC275	237
110SC300	262
110SC325	287
110SC350	312
110SC375	336
110SC430	392
110SC500	462
Special widths	F= C-93

Bright Zinc Plated Steel Type Part Number

Chain type	End Brackets kit
110SC A110SC	□□□ KM □**

Chain type	End Brackets kit
110SC A110SC	□□□ K □**

Available on request in stainless steel.
** 1=Pos.1; 2=Pos.2; 3=Pos.3
See mounting variations page 31

Tiewrap Clamp kit mounted on female attachment

Part Number
Assembled SFCT110□□□*FKM
Unassembled SFCT110□□□*FK
* Inner width (C)

Tiewrap Clamp kit mounted on male attachment

Part Number
Assembled SFCT110□□□*MKM
Unassembled SFCT110□□□*MK
* Inner width (C)

Serie Heavy

H110SC

Nylon chain with opening frame with a snap



H110B

On request can be supplied with rods made of stainless steel or bright zinc plated steel.

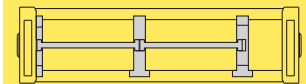

Separation System page 216

How to open the frame



How to release the pin junction

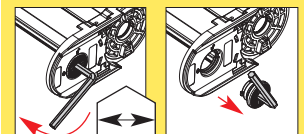

10 mm



Suitable to long travel distance in frame every pitch version.

For further informations please consult Brevetti Stendalto's Technical Office

Serie Heavy

H110T

Nylon chain with aluminium draw plates

Inner height (D) 112,5 mm

Sideband construction with quickly removable pin.
 Alu-draw frames are un-screwable from inner and outer radius.
 As standard the chain comes with frames every link.
 Vertical separators system available.

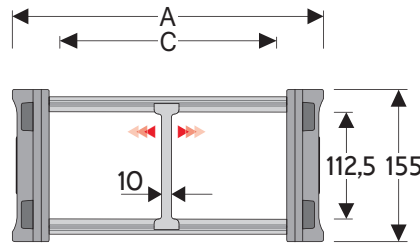

Separator

- Unassembled	Part.no S310TCF9
- Assembled	Part.no S310TCF9MC
Pin	
	Part.no PNH110RS

Technical characteristics when self-supported

Speed	4 m/s
Acceleration	20 m/s ²

For higher requirements please consult our technical dept.

For sliding applications, characteristics techniques may vary depending on the frequency, added weight and work environment.

A	B	C	D	R	Weight/m	Chain
mm	mm	mm	mm	mm	kg	Part Number
255	155	200	112,5	200-250-300-400-500-600-700-750	9,93	110T200 □□□ *
355	155	300	112,5	200-250-300-400-500-600-700-750	10,96	110T300 □□□ *
455	155	400	112,5	200-250-300-400-500-600-700-750	12,00	110T400 □□□ *
555	155	500	112,5	200-250-300-400-500-600-700-750	13,04	110T500 □□□ *
655	155	600	112,5	200-250-300-400-500-600-700-750	14,08	110T600 □□□ *
C+55	155	112,5	200-250-300-400-500-600-700-750		110T □□□□□ **

*Complete the code by inserting the value of the radius (R): Ex. 110T200 □□□ □

**Complete the code by inserting the value of the quote C and the radius (R): Ex. 110T□□□□□□□□

4

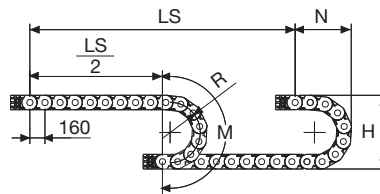
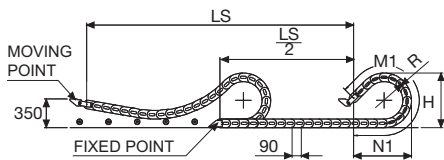

Length of chain (L)

Half travel distance ($\frac{LS}{2}$)

plus length of curve (M) or (M1)

$$L = \frac{LS}{2} + M \text{ or } M1$$

R	H	N	M	N1	M1
mm	mm	mm	mm	mm	mm
200	557	418	950	855	1820
250	657	468	1110	1095	2375
300	757	518	1265	1335	2935
400	957	618	1580	1805	4045
500	1157	718	1895	2280	5160
600	1357	818	2205	2750	6270
700	1557	918	2520	3225	7385
750	1657	968	2680	3460	7940



Version with Alu-draw mounted on every pitch

Self-Supporting Capacity Diagram

The maximum length of the self-supporting capacity or in admissible sagging ($\frac{LS}{2}$) in relationship to the weight of the cables and hoses contained per linear metre.

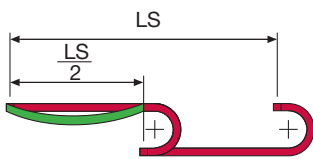
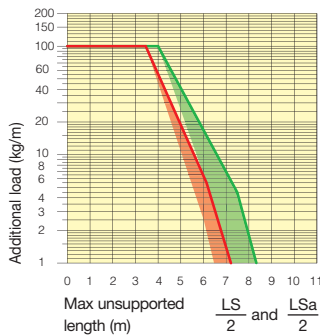

The area in the diagram considers the difference of weight between various widths of chain with nylon frame every second link.

Red for self-supporting chain, green for chain in admissible sagging.

For applications with ($\frac{LS}{2}$) and weights not included in the diagram of self-supporting capacity, verify the possible use of support rollers (see page 30).

Bright Zinc Plated Steel End Bracket***

The end brackets set allows the two ends of the chain to be attached to the equipment. Set complete with tie-wrap clamps available on request.

Bright Zinc Plated Steel Type

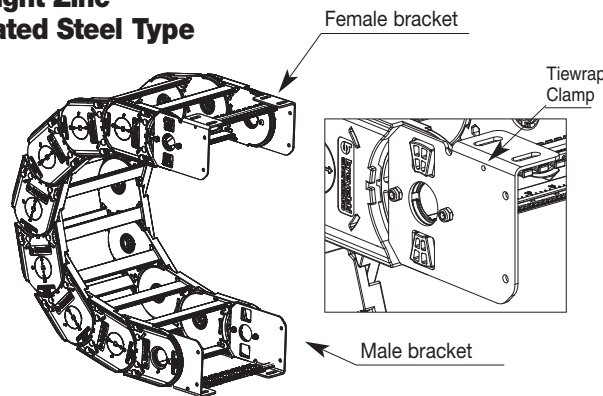
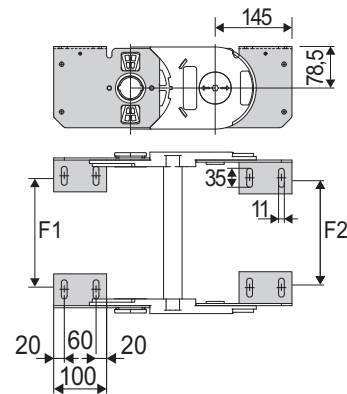

Fig. A
Chain fixed outside/inside the radius. (Fig A)
See mounting options page 31



Chain Type	F1 mm
110T200	170
110T300	270
110T400	370
110T500	470
110T600	570
Special widths	F=C-30

Catena Tipo	F2 mm
110T200	162
110T300	262
110T400	362
110T500	462
110T600	562
Special widths	F=C-38

Bright Zinc Plated Steel Type Part Number

Complete Set assembled	Part Number
Chain End Brackets	
Type Set	
110T...	A110KM□□**

Complete Set Unassembled	Part Number
Chain End Brackets	
Type Set	
110T...	A110T□□□K□**

** 1= Pos.1; 2= Pos.2; 3= Pos.3
*** On request stainless steel

Tiewrap Clamp kit mounted on female attachment

Complete Set assembled	Part Number
Chain End Brackets	
Type Set	
Assembled	SFCT110□□□*MKM
Unassembled	SFCT110□□□*FK
* Inner width (C)	

Tiewrap Clamp kit mounted on male attachment

Complete Set assembled	Part Number
Chain End Brackets	
Type Set	
Assembled	SFCT110□□□*MKM
Unassembled	SFCT110□□□*MK
* Inner width (C)	

Serie Heavy

H110T

Nylon chain with aluminium draw plates



H110B
On request can be supplied with rods made of stainless steel or bright zinc plated steel.



How to release the pin junction

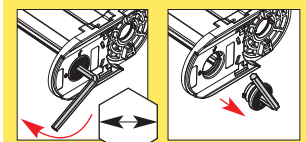

CH.10 mm



Suitable to long travel distance in frame every pitch version.

For further informations please consult Brevetti Stendaito's Technical Office

Serie Heavy

306SU

Nylon Cable Chain with opening frames

Inner height (D) 37 mm

Strong double share Sideband & Frame construction with large anti-friction triple-pin. Frames opening from inner and outer radius.

As standard the chain comes with frames every second link, on request with frames every link.

Vertical and horizontal modular separator system is available.

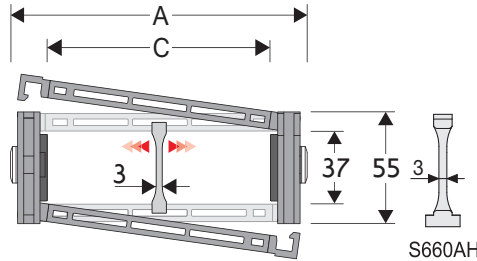

Separator

- Unassembled Part.no S306SM
- Assembled* Part.no S306SMMC

Strong-hold separator

for C > 250 mm

- Unassembled Part.no S660AH
- Assembled* Part.no S660AHMCI
- Assembled** Part.no S660AHMCE

Pin

- Part.no PG307

* for chain opening outer radius
** for chain opening inner radius

Technical characteristics when self-supported

Speed	4 m/s
Acceleration	10 m/s ²

For higher requirements please consult our technical dept.

4

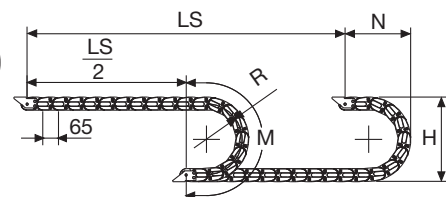

Length of chain (L)

Half travel distance ($\frac{LS}{2}$)

plus length of curve (M)

$$L = \frac{LS}{2} + M$$

R	H	N	M
mm	mm	mm	mm
075	208	170	370
107	272	205	470
150	358	245	605
200	458	295	760
250	558	345	920
300	658	395	1075

A	B	C	D	R	Weight/m	Chain
mm	mm	mm	mm	mm	kg	Part Number
79	55	43	37	075-107-150-200-250-300	1,61	306SU043 □□□ *
90	55	54	37	075-107-150-200-250-300	1,61	306SU054 □□□ *
104	55	68	37	075-107-150-200-250-300	1,68	306SU068 □□□ *
110	55	74	37	075-107-150-200-250-300	1,70	306SU074 □□□ *
114	55	78	37	075-107-150-200-250-300	1,72	306SU078 □□□ *
124	55	88	37	075-107-150-200-250-300	1,74	306SU088 □□□ *
129	55	93	37	075-107-150-200-250-300	1,74	306SU093 □□□ *
136	55	100	37	075-107-150-200-250-300	1,76	306SU100 □□□ *
146	55	110	37	075-107-150-200-250-300	1,77	306SU110 □□□ *
154	55	118	37	075-107-150-200-250-300	1,82	306SU118 □□□ *
165	55	129	37	075-107-150-200-250-300	1,85	306SU129 □□□ *
179	55	143	37	075-107-150-200-250-300	1,89	306SU143 □□□ *
204	55	168	37	075-107-150-200-250-300	1,96	306SU168 □□□ *
229	55	193	37	075-107-150-200-250-300	2,04	306SU193 □□□ *
240	55	204	37	075-107-150-200-250-300	2,07	306SU204 □□□ *
254	55	218	37	075-107-150-200-250-300	2,11	306SU218 □□□ *
281	55	245	37	075-107-150-200-250-300	2,19	306SU245 □□□ *
290	55	254	37	075-107-150-200-250-300	2,22	306SU254 □□□ *
315	55	279	37	075-107-150-200-250-300	2,29	306SU279 □□□ *
341	55	305	37	075-107-150-200-250-300	2,34	306SU305 □□□ *
363	55	327	37	075-107-150-200-250-300	2,41	306SU327 □□□ *
391	55	355	37	075-107-150-200-250-300	2,49	306SU355 □□□ *

*Complete the code by inserting the value of the radius (R): Ex. 306SU110
Chain equipped with nylon frame every pitch: complete the code by inserting the letter D.
Ex. 306SU110150



Self-Supporting Capacity Diagram

The maximum length of the self-supporting capacity ($\frac{LS}{2}$) in relationship to the weight of the cables and hoses contained per linear metre.

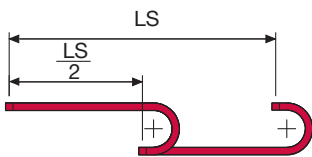
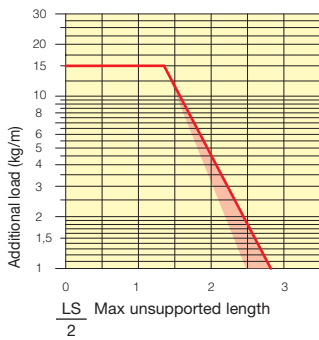

The red marking in the diagram area considers the difference of weight between various widths of chains assembled with nylon frames every second pitch.

For applications with $\frac{LS}{2}$ and weights not included in the area of the diagram showing self-supporting capacity, verify the possible use of support rollers (see page 30).

End Brackets

The end brackets set allows the two ends of the chain to be attached to the equipment. Set complete with tie-wrap clamps available on request.

Nylon Type

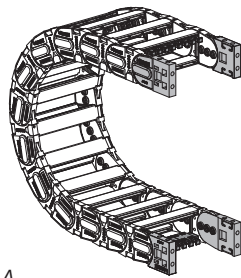

Fig. A
The chain can be fixed frontally, inner or outer radius. (Fig A)

Nylon Type

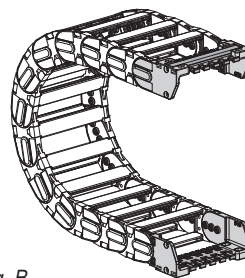
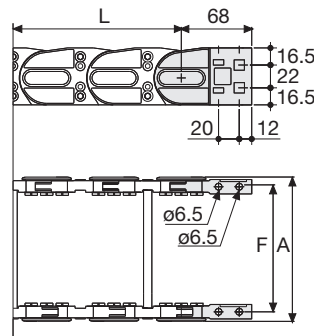

Fig. B
Chain fixed outside the radius. (Fig B)
See end brackets mounting variations page 31.



Chain Type	F mm
306SU043	61
306SU054	72
306SU068	86
306SU074	92
306SU078	96
306SU088	106
306SU093	111
306SU100	118
306SU110	128
306SU118	136
306SU129	147
306SU143	161
306SU168	186
306SU193	211
306SU204	222
306SU218	236
306SU245	263
306SU254	272
306SU279	297
306SU305	323
306SU327	345
306SU355	373

Nylon Type Part Numbers

Complete Set Assembled	
Chain Type	End Brackets Set
306SU...	AN306KM
Complete Set Unassembled	
Chain Type	End Brackets Set
306SU...	AN306K
Tiewrap Clamp	
Assembl.	CFC306S □□□*KM
Unassembl.	CFC306S □□□*K

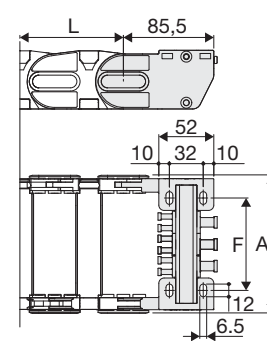

Chain Type	F mm
306SU043	36
306SU054	47
306SU068	61
306SU074	67
306SU078	71
306SU088	81
306SU093	86
306SU100	93
306SU110	103
306SU118	111
306SU129	122
306SU143	136
306SU168	161
306SU193	186
306SU204	197
306SU218	211
306SU245	238
306SU254	247
306SU279	272
306SU305	298
306SU327	320
306SU355	348

Nylon Type Part Numbers

Complete Set Assembled	
Chain Type	End Brackets Set
306SU...	ANL306KM □**
Complete Set Unassembled	
Chain Type	End Brackets Set
306SU...	ANL306K □**
Tiewrap Clamp	
Assembl.	SFCTL306□□□*KM
Unassembl.	SFCTL306S□□□*K
SFCTL not applicable for C=43	

Serie Heavy

306SU

Nylon Cable Chain with opening frames

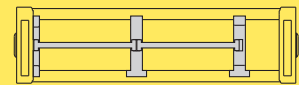

Separation System To choose the separators see page 216

Bright Zinc Plated Steel Type***

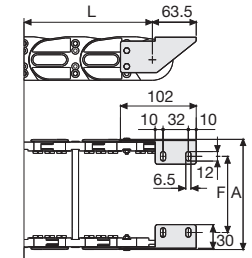
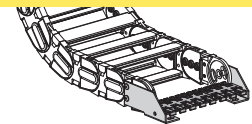

F = A-43

Bright Zinc Plated Steel Type Part Numbers

Complete Set Assembled	
Chain Type	End Brackets Set
306SU...	A306SKM □**
Complete Set Unassembled	
Chain Type	End Brackets Set
306SU...	A306SK □**
Tiewrap Clamp	
Assembl.	SFCT306S □□□*KM
Unassembl.	SFCT306S □□□*K

* Inner width (C)
** 1=Pos.1; 2=Pos.2; 3=Pos.3
*** Available on request in stainless steel

Serie Heavy

306B

Nylon Cable Chain with un-screwable aluminium rods

Inner height (D) 30 mm

Strong double share Sideband & Frame construction with large anti-friction triple-pin. Alu-rod frames are un-screwable from inner and outer radius. As standard the chain comes with frames every second link, on request with frames every link. Vertical and horizontal separator systems are available.

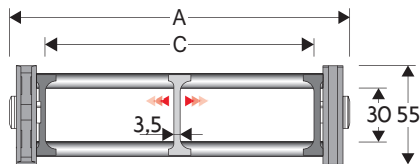

Separator

- Unassembled	Part.no S2000F
- Assembled	Part.no S2000FMC

Pin

Part.no PG307

Technical characteristics when self-supported

Speed	4 m/s
Acceleration	10 m/s ²

For higher requirements please consult our technical dept.

A	B	C	D	R	Weight/m	Chain
mm	mm	mm	mm	mm	kg	Part Number
115	55	75	30	075-107-150-200-250-300	1,60	306B075 □ *
140	55	100	30	075-107-150-200-250-300	1,65	306B100 □ *
190	55	150	30	075-107-150-200-250-300	1,80	306B150 □ *
240	55	200	30	075-107-150-200-250-300	1,90	306B200 □ *
290	55	250	30	075-107-150-200-250-300	2,00	306B250 □ *
340	55	300	30	075-107-150-200-250-300	2,15	306B300 □ *
C+40	55	30	075-107-150-200-250-300		306B □ □ □ □ **

*Complete the code by inserting the value of the radius (R): Ex. 306B075 □

Where: 1=075; 2=107; 3=150; 4=200; 5=250; 6=300.

**Complete the code by inserting the value of the quote C and the radius (R): Ex. 306B □ □ □ □ □

Chain equipped with aluminium rods every pitch: complete the code by inserting the letter D.

Ex. 306B0751 □

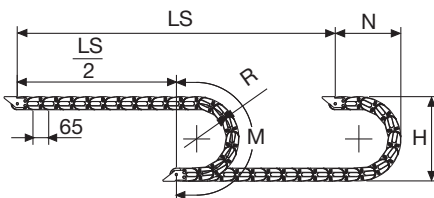

R	H	N	M
mm	mm	mm	mm
075	208	170	370
107	272	205	470
150	358	245	605
200	458	295	760
250	558	345	920
300	658	395	1075

Length of chain (L)

Half travel distance ($\frac{LS}{2}$)

plus length of curve (M)

$$L = \frac{LS}{2} + M$$

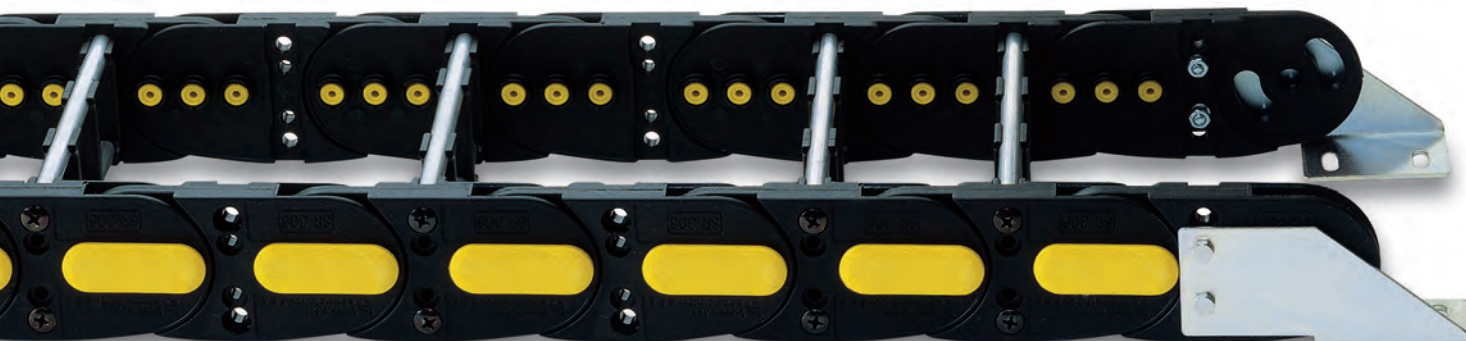

Self-Supporting Capacity Diagram

The maximum length of the self-supporting capacity ($\frac{LS}{2}$) in relationship to the weight of the cables and hoses contained per linear metre.

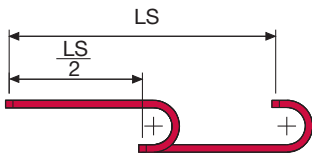
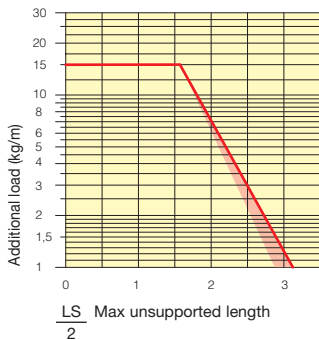

The red marking in the diagram area considers the difference of weight between various widths of chains assembled with rods every second pitch.

For applications with $\frac{LS}{2}$ and weights not included in the area of the diagram showing self-supporting capacity, verify the possible use of support rollers (see page 30).

End Brackets

The end brackets set allows the two ends of the chain to be attached to the equipment. Set complete with tie-wrap clamps available on request.

Nylon Type

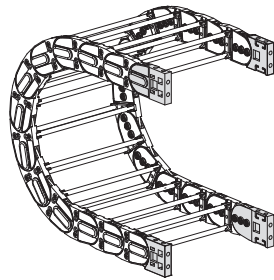

Fig. A
The chain can be fixed frontally, inner or outer radius. (Fig A)

Nylon Type

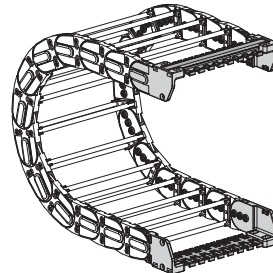
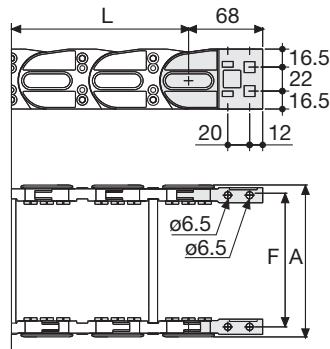

Fig. B
Chain fixed outside the radius. (Fig B)
See end brackets mounting variations page 31.



Chain Type	F mm
306B075	96
306B100	121
306B150	171
306B200	221
306B250	271
306B300	321
Special widths F=A-19	

Nylon Type Part Numbers

Complete Set Assembled	
Chain Type	End Brackets Set
306B...	AN306KM
Complete Set Unassembled	
Chain Type	End Brackets Set
306B...	AN306K

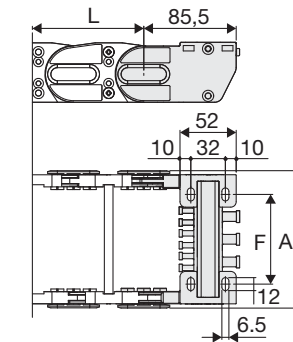

Chain Type	F mm
306B075	71
306B100	96
306B150	146
306B200	196
306B250	246
306B300	296
Special widths F=A-44	

Nylon Type Part Numbers

Complete Set Assembled	
Chain Type	End Brackets Set
306B...	ANL306KM □**
Complete Set Unassembled	
Chain Type	End Brackets Set
306B...	ANL306K □**
Tiewrap Clamp	
Assembl.	SFCTL306 □□□*KM
Unassembl.	SFCTL306B □□□*K

Serie Heavy

306B Nylon Cable Chain with un-screwable aluminium rods

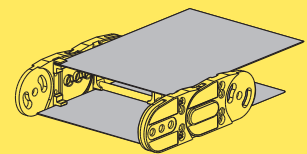

Steel laminar cover.

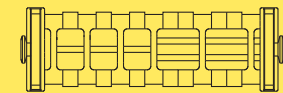

Supplementary movable separators.

Bright Zinc Plated Steel Type***

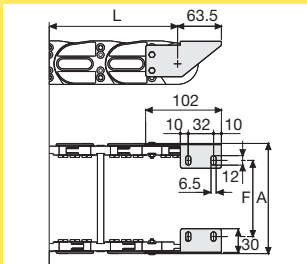
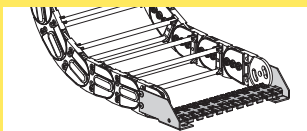

F = A-44

Bright Zinc Plated Steel Type Part Numbers

Complete Set Assembled	
Chain Type	End Brackets Set
306B...	A306KM □**
Complete Set Unassembled	
Chain Type	End Brackets Set
306B...	A306K □**
Tiewrap Clamp	
Assembl.	SFCT306B □□□*KM
Unassembl.	SFCT306B □□□*K

* Inner width (C)
** 1=Pos.1; 2=Pos.2; 3=Pos.3
*** Available on request in stainless steel

Serie Heavy

307SU

Nylon Cable Chain with opening frames

Inner height (D) 47 mm

Strong double share Sideband & Frame construction with large anti-friction triple-pin. Frames opening from inner and outer radius.

As standard the chain comes with frames every second link, on request with frames every link.

Vertical and horizontal modular separator system is available.

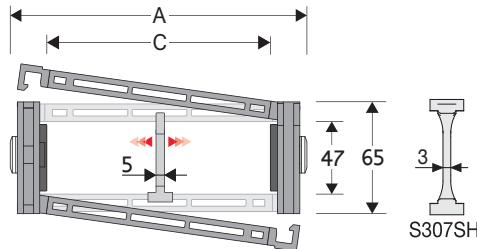

Separator	
- Unassembled	Part.no S307S
- Assembled*	Part.no S307SMCI
- Assembled**	Part.no S307SMCE
Strong-hold separator	
for C > 250 mm	
- Unassembled	Part.no S307SH
- Assembled*	Part.no S307SHMCI
- Assembled**	Part.no S307SHMCE
Pin	
	Part.no PG307

* for chain opening outer radius
** for chain opening inner radius

Technical characteristics when self-supported

Speed	8 m/s
Acceleration	40 m/s ²

For higher requirements please consult our technical dept.

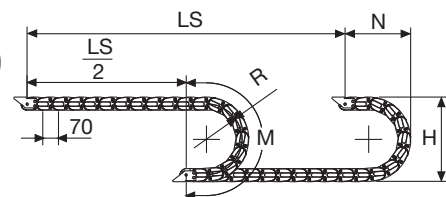

Length of chain (L)
Half travel distance ($\frac{LS}{2}$)
plus length of curve (M)

$$L = \frac{LS}{2} + M$$

R	H	N	M
mm	mm	mm	mm
075	219	180	375
090	249	195	425
120	309	225	520
140	349	245	580
200	469	305	770
250	569	355	925

A	B	C	D	R	Weight/m	Chain
mm	mm	mm	mm	mm	kg	Part Number
80	65	42	47	075-090-120-140-200-250	1,86	307SU042 □□□ *
91	65	53	47	075-090-120-140-200-250	1,86	307SU053 □□□ *
105	65	67	47	075-090-120-140-200-250	1,92	307SU067 □□□ *
111	65	73	47	075-090-120-140-200-250	1,94	307SU073 □□□ *
115	65	77	47	075-090-120-140-200-250	1,96	307SU077 □□□ *
125	65	87	47	075-090-120-140-200-250	1,97	307SU087 □□□ *
130	65	92	47	075-090-120-140-200-250	1,97	307SU092 □□□ *
137	65	99	47	075-090-120-140-200-250	1,99	307SU099 □□□ *
147	65	109	47	075-090-120-140-200-250	2,00	307SU109 □□□ *
155	65	117	47	075-090-120-140-200-250	2,05	307SU117 □□□ *
166	65	128	47	075-090-120-140-200-250	2,07	307SU128 □□□ *
180	65	142	47	075-090-120-140-200-250	2,10	307SU142 □□□ *
205	65	167	47	075-090-120-140-200-250	2,16	307SU167 □□□ *
230	65	192	47	075-090-120-140-200-250	2,23	307SU192 □□□ *
241	65	203	47	075-090-120-140-200-250	2,26	307SU203 □□□ *
255	65	217	47	075-090-120-140-200-250	2,30	307SU217 □□□ *
282	65	244	47	075-090-120-140-200-250	2,37	307SU244 □□□ *
291	65	253	47	075-090-120-140-200-250	2,39	307SU253 □□□ *
316	65	278	47	075-090-120-140-200-250	2,47	307SU278 □□□ *
342	65	304	47	075-090-120-140-200-250	2,50	307SU304 □□□ *
364	65	326	47	075-090-120-140-200-250	2,56	307SU326 □□□ *
392	65	354	47	075-090-120-140-200-250	2,63	307SU354 □□□ *

*Complete the code by inserting the value of the radius (R): Ex. 307SU117 □□□□
Chain equipped with nylon frame every pitch: complete the code by inserting the letter D.
Ex. 307SU117140 □□



Self-Supporting Capacity Diagram

The maximum length of the self-supporting capacity ($\frac{LS}{2}$) in relationship to the weight of the cables and hoses contained per linear metre.

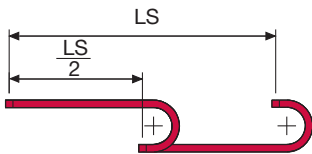
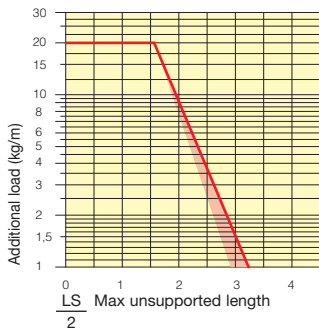

The red marking in the diagram area considers the difference of weight between various widths of chains assembled with nylon frames every second pitch.

For applications with $\frac{LS}{2}$ and weights not included in the area of the diagram showing self-supporting capacity, verify the possible use of support rollers (see page 30).

End Brackets

The end brackets set allows the two ends of the chain to be attached to the equipment. Set complete with tie-wrap clamps available on request.

Nylon Type

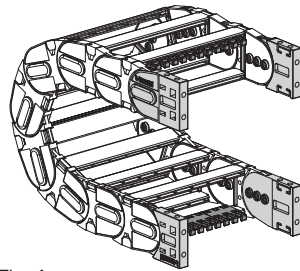
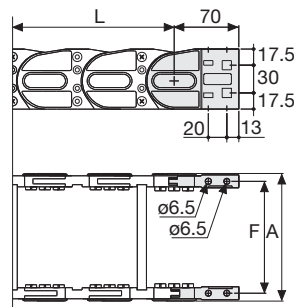

Fig. A
The chain can be fixed frontally, inner or outer radius. (Fig A)



Chain Type	F mm
307SU042	61
307SU053	72
307SU067	86
307SU073	92
307SU077	96
307SU087	106
307SU092	111
307SU099	118
307SU109	128
307SU117	136
307SU128	147
307SU142	161
307SU167	186
307SU192	211
307SU203	222
307SU217	236
307SU244	263
307SU253	272
307SU278	297
307SU304	323
307SU326	345
307SU354	373

Nylon Type Part Numbers

Complete Set Assembled Chain Type	End Brackets Set
307SU...	AN307KM

Complete Set Unassembled Chain Type	End Brackets Set
307SU...	AN307K

Tiewrap Clamp
Assembl. CFC307S □□□ *KM
Unassembl. CFC307S □□□ *K

Bright Zinc Plated Steel Type***

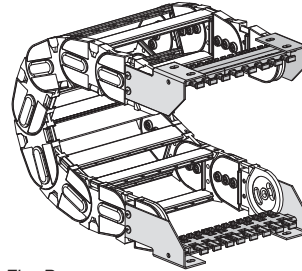
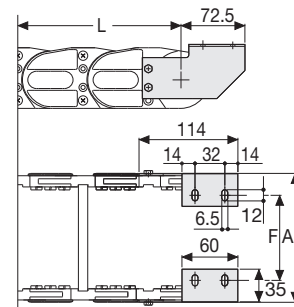

Fig. B
Chain fixed outside the radius. (Fig B)
See end brackets mounting variations page 31.



Chain Type	F mm
307SU042	31
307SU053	42
307SU067	56
307SU073	62
307SU077	66
307SU087	76
307SU092	81
307SU099	88
307SU109	98
307SU117	106
307SU128	117
307SU142	131
307SU167	156
307SU192	181
307SU203	192
307SU217	206
307SU244	233
307SU253	242
307SU278	267
307SU304	293
307SU326	315
307SU354	343

Bright Zinc Plated Steel Type Part Numbers

Complete Set Assembled Chain Type	End Brackets Set
307SU...	A307SKM □**

Complete Set Unassembled Chain Type	End Brackets Set
307SU...	A307SK □**

Tiewrap Clamp
Assembl. SFCT307S □□□ *KM
Unassembl. SFCT307S □□□ *K

* Inner width (C)
** 1=Pos.1; 2=Pos.2; 3=Pos.3
*** Available on request in stainless steel

Serie Heavy

307SU

Nylon Cable Chain with opening frames

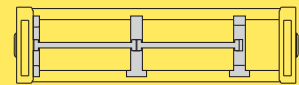

Separation System
To choose the separators see page 216.



How to open the cover.

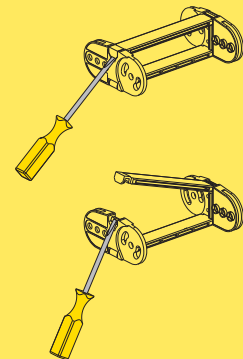

Special tool to remove the connecting pivots:
Part Number PZ036.



For further information please consult Brevetti Stendalto's Technical Office

Serie Heavy

307B

Nylon Cable Chain with un-screwable aluminium rods

Inner height (D) 40 mm

Strong double share Sideband & Frame construction with large anti-friction triple-pin. Alu-rod frames are un-screwable from inner and outer radius. As standard the chain comes with frames every second link, on request with frames every link. Vertical and horizontal separator systems are available.

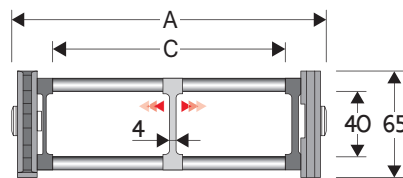

Separator

- Unassembled	Part.no S307
- Assembled	Part.no S307MC
Pin	
	Part.no PG307

Technical characteristics when self-supported

Speed	8 m/s
Acceleration	40 m/s ²

For higher requirements please consult our technical dept.

A	B	C	D	R	Weight/m	Chain
mm	mm	mm	mm	mm	kg	Part Number
117	65	75	40	075-090-120-140-200-250	1,80	307B075 □ *
142	65	100	40	075-090-120-140-200-250	1,85	307B100 □ *
192	65	150	40	075-090-120-140-200-250	1,95	307B150 □ *
242	65	200	40	075-090-120-140-200-250	2,05	307B200 □ *
292	65	250	40	075-090-120-140-200-250	2,15	307B250 □ *
342	65	300	40	075-090-120-140-200-250	2,25	307B300 □ *
C+42	65	40	075-090-120-140-200-250		307B □ □ □ □ **

*Complete the code by inserting the value of the radius (R): Ex. 307B075 □

Where: 0=090; 1=120; 2=140; 3=200; 4=250; 7=075

**Complete the code by inserting the value of the quote C and the radius (R): Ex. 307B □ □ □ □ □

Chain equipped with aluminium rods every pitch: complete the code by inserting the letter D. Ex. 307B0751 □

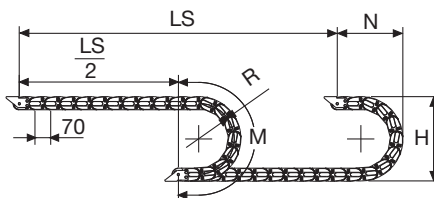

Length of chain (L)
Half travel distance ($\frac{LS}{2}$)
plus length of curve (M)

$$L = \frac{LS}{2} + M$$

R	H	N	M
mm	mm	mm	mm
075	219	180	375
090	249	195	425
120	309	225	520
140	349	245	580
200	469	305	770
250	569	355	925



Self-Supporting Capacity Diagram

The maximum length of the self-supporting capacity ($\frac{LS}{2}$) in relationship to the weight of the cables and hoses contained per linear metre.

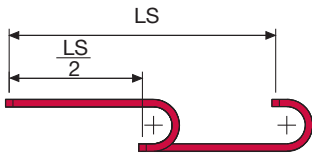
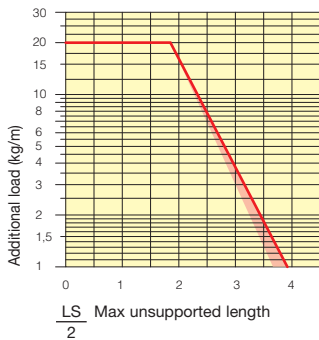

The red marking in the diagram area considers the difference of weight between various widths of chains assembled with rods every second pitch.

For applications with $\frac{LS}{2}$ and weights not included in the area of the diagram showing self-supporting capacity, verify the possible use of support rollers (see page 30).

End Brackets

The end brackets set allows the two ends of the chain to be attached to the equipment. Set complete with tie-wrap clamps available on request.

Nylon Type

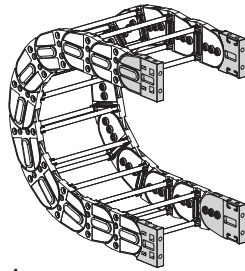

Fig. A The chain can be fixed frontally, inner or outer radius. (Fig A)

Bright Zinc Plated Steel Type***

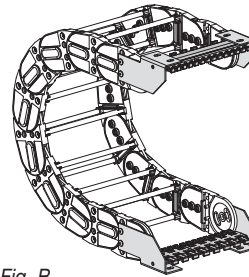
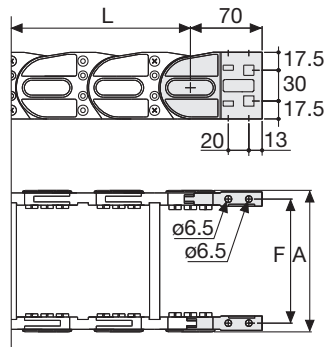

Fig. B Chain fixed outside the radius. (Fig B) See end brackets mounting variations page 31.



Chain Type	F mm
307B075	98
307B100	123
307B150	173
307B200	223
307B250	273
307B300	323
Special widths F=A-19	

Nylon Type Part Numbers

Complete Set Assembled Chain Type	End Brackets Set
307B...	AN307KM

Complete Set Unassembled Chain Type	End Brackets Set
307B...	AN307K

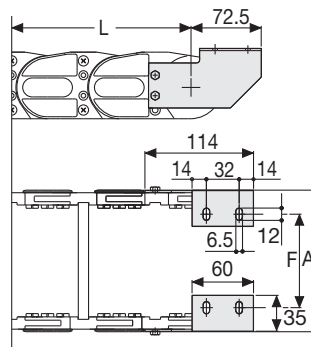

Chain Type	F mm
307B075	68
307B100	93
307B150	143
307B200	193
307B250	243
307B300	293
Special widths F=A-49	

Bright Zinc Plated Steel Type Part Numbers

Complete Set Assembled Chain Type	End Brackets Set
307B...	A307KM □ **

Complete Set Unassembled Chain Type	End Brackets Set
307B...	A307K □ **

Tiewrap Clamp
 Assembl. SFCT307B □□□*KM
 Unassembl. SFCT307B □□□*K
 * Inner width (C)
 ** 1=Pos.1; 2=Pos.2; 3=Pos.3
 *** Available on request in stainless steel

Serie Heavy

307B

Nylon Cable Chain with un-screwable aluminium rods

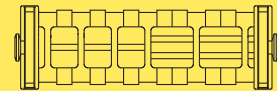

Supplementary movable separators.

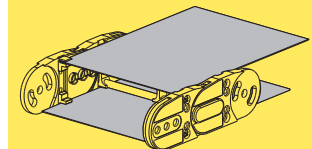

Steel laminar cover.

Special tool to remove the connecting pivots: Part Number PZ036.



For further information please consult Brevetti Stendalto's Technical Office

Serie Heavy

307E Nylon Cable Chain with alu-drawn frames

Inner height (D) 46,5 mm

Strong side-bands chain with dovetailed links and triple low friction pins. Alu-drawn frames mounted each second pitch full-pitch frames version available on demand.

Special C size available on demand. Vertical and horizontal separator systems are available.

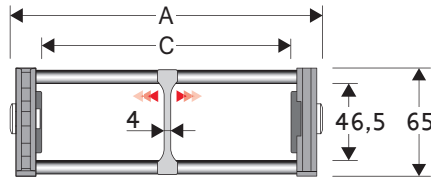

Separator

- Unassembled	Part.no S307EF
- Assembled	Part.no S307EFMC

Pin

Part.no PG307

Technical characteristics when self-supported

Speed	8 m/s
Acceleration	40 m/s ²

For higher requirements please consult our technical dept.

A	B	C	D	R	Weight/m	Chain
mm	mm	mm	mm	mm	kg	Part Number
113	65	75	46,5	075-090-120-140-170-200-250	1,95	307E075□□□*
138	65	100	46,5	075-090-120-140-170-200-250	2,00	307E100□□□*
188	65	150	46,5	075-090-120-140-170-200-250	2,15	307E150□□□*
238	65	200	46,5	075-090-120-140-170-200-250	2,25	307E200□□□*
288	65	250	46,5	075-090-120-140-170-200-250	2,35	307E250□□□*
338	65	300	46,5	075-090-120-140-170-200-250	2,50	307E300□□□*
C+38	65	46,5	075-090-120-140-170-200-250		307E□□□□□□**

Complete the code by inserting the value of the radius (R): Ex. 307E075□□□

**Complete the code by inserting the value of the quote C and the radius (R): Ex. 307E□□□□□□*

Chain equipped with alu-drawn frames full-pitch: complete the code by inserting the letter D.
Ex. 307E075120□

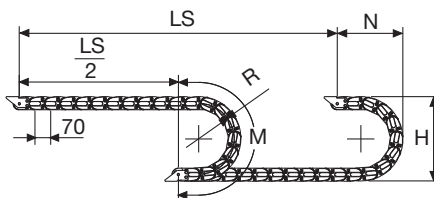

Length of chain (L)

Half travel distance ($\frac{LS}{2}$)
plus length of curve (M)

$$L = \frac{LS}{2} + M$$

R	H	N	M
mm	mm	mm	mm
075	219	180	380
090	249	195	425
120	309	225	520
140	349	245	580
170	409	275	675
200	469	305	770
250	569	355	930



Version alu-drawn frames mounted each second pitch.

Self-Supporting Capacity Diagram

The maximum length of the self-supporting capacity ($\frac{LS}{2}$) in relationship to the weight of the cables and hoses contained per linear metre.

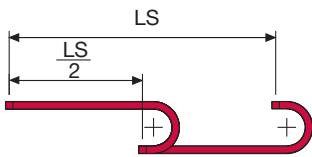
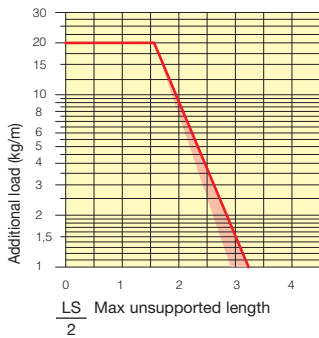

The red marking in the diagram area considers the difference of weight between various widths of chains assembled with alu-drawn frames every second pitch.

For applications with $\frac{LS}{2}$ and weights not included in the area of the diagram showing self-supporting capacity, verify the possible use of support rollers (see page 30).

End Brackets

The end brackets set allows the two ends of the chain to be attached to the equipment. Set complete with tie-wrap clamps available on request.

Nylon Type

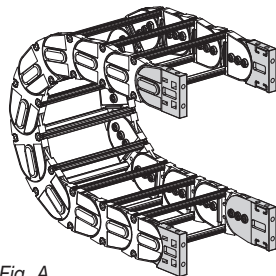

Fig. A
The chain can be fixed frontally, inner or outer radius. (Fig A)

Bright Zinc Plated Steel Type***

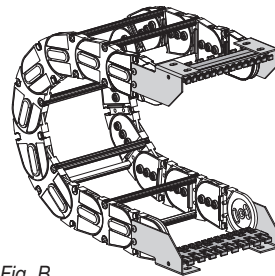
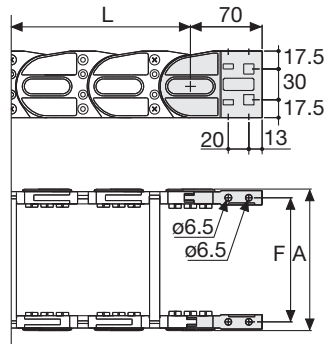

Fig. B
Chain fixed outside the radius. (Fig B)
See end brackets mounting variations page 31.



Chain Type	F mm
307E075	94
307E100	119
307E150	169
307E200	219
307E250	269
307E300	319
Special widths F=A-19	

Nylon Type Part Numbers

Complete Set Assembled	
Chain	End Brackets
Type	Set
307E...	AN307KM

Complete Set Unassembled	
Chain	End Brackets
Type	Set
307E...	AN307K

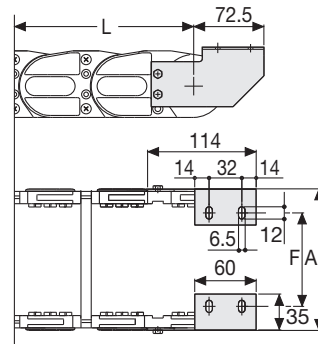

Chain Type	F mm
307E075	64
307E100	89
307E150	139
307E200	189
307E250	239
307E300	289
Special widths F=A-49	

Bright Zinc Plated Steel Type Part Numbers

Complete Set Assembled	
Chain	End Brackets
Type	Set
307E...	A307EKM□**

Complete Set Unassembled	
Chain	End Brackets
Type	Set
307E...	A307EK□**

Tiewrap Clamp

Assembl. SFCT307E□□□*KM
Unassembl. SFCT307E□□□*K

* Inner width (C)

** 1=Pos.1; 2=Pos.2; 3=Pos.3

*** Available on request in stainless steel

Serie Heavy

307E

Nylon Cable Chain with alu-drawn frames

4

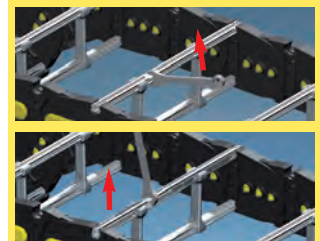

How to open alu-drawn frames

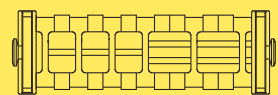

Supplementary movable separators.

Special tool to remove the connecting pivots:
Part Number PZ036.



For further information please consult Brevetti Stendalto's Technical Office

Serie Heavy

308SU

Nylon Cable Chain with opening frames

Inner height (D) 57 mm

Strong double share Sideband & Frame construction with large anti-friction triple-pin. Frames opening from inner and outer radius. As standard the chain comes with frames every second link, on request with frames every link. Vertical and horizontal modular separator system is available.

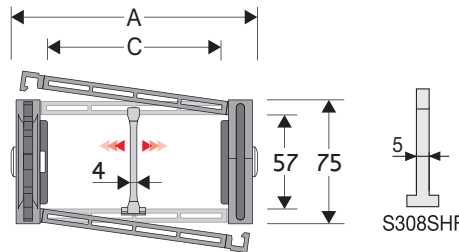

Separator

- Unassembled	Part.no S308C
- Assembled*	Part.no S308CMCI
- Assembled**	Part.no S308CMCE

Strong-hold separator

for C > 250 mm

- Unassembled	Part.no S308SHF
- Assembled*	Part.no S308SHFMC1
- Assembled**	Part.no S308SHFMCE

Pin

Part.no PG308

* for chain opening outer radius
** for chain opening inner radius

Technical characteristics when self-supported

Speed	8 m/s
Acceleration	40 m/s ²

For higher requirements please consult our technical dept.

A	B	C	D	R	Weight/m	Chain
mm	mm	mm	mm	mm	kg	Part Number
82	75	38	57	135-150-180-200-230-280-300-400-600	2,46	308SU038 □□□ *
93	75	49	57	135-150-180-200-230-280-300-400-600	2,46	308SU049 □□□ *
107	75	63	57	135-150-180-200-230-280-300-400-600	2,51	308SU063 □□□ *
113	75	69	57	135-150-180-200-230-280-300-400-600	2,53	308SU069 □□□ *
117	75	73	57	135-150-180-200-230-280-300-400-600	2,54	308SU073 □□□ *
127	75	83	57	135-150-180-200-230-280-300-400-600	2,56	308SU083 □□□ *
132	75	88	57	135-150-180-200-230-280-300-400-600	2,56	308SU088 □□□ *
139	75	95	57	135-150-180-200-230-280-300-400-600	2,58	308SU095 □□□ *
149	75	105	57	135-150-180-200-230-280-300-400-600	2,59	308SU105 □□□ *
157	75	113	57	135-150-180-200-230-280-300-400-600	2,62	308SU113 □□□ *
168	75	124	57	135-150-180-200-230-280-300-400-600	2,65	308SU124 □□□ *
182	75	138	57	135-150-180-200-230-280-300-400-600	2,67	308SU138 □□□ *
207	75	163	57	135-150-180-200-230-280-300-400-600	2,73	308SU163 □□□ *
232	75	188	57	135-150-180-200-230-280-300-400-600	2,79	308SU188 □□□ *
243	75	199	57	135-150-180-200-230-280-300-400-600	2,81	308SU199 □□□ *
257	75	213	57	135-150-180-200-230-280-300-400-600	2,84	308SU213 □□□ *
284	75	240	57	135-150-180-200-230-280-300-400-600	2,90	308SU240 □□□ *
293	75	249	57	135-150-180-200-230-280-300-400-600	2,92	308SU249 □□□ *
318	75	274	57	135-150-180-200-230-280-300-400-600	2,99	308SU274 □□□ *
344	75	300	57	135-150-180-200-230-280-300-400-600	3,02	308SU300 □□□ *
366	75	322	57	135-150-180-200-230-280-300-400-600	3,07	308SU322 □□□ *
394	75	350	57	135-150-180-200-230-280-300-400-600	3,13	308SU350 □□□ *

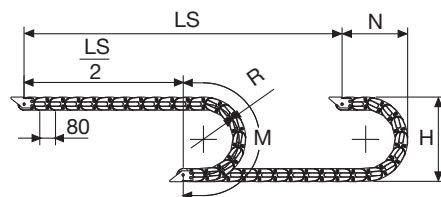

Length of chain (L)
Half travel distance ($\frac{LS}{2}$)
plus length of curve (M)

$$L = \frac{LS}{2} + M$$

R	H	N	M
mm	mm	mm	mm
135	345	255	585
150	375	270	635
180	435	300	725
200	475	320	790
230	535	350	885
280	635	400	1040
300	675	420	1105
400	875	520	1420
600	1275	720	2045

*Complete the code by inserting the value of the radius (R): Ex. 308SU105 □ □ □ □
Chain equipped with nylon frame every pitch: complete the code by inserting the letter D.
Ex. 308SU105150 □ □



Self-Supporting Capacity Diagram

The maximum length of the self-supporting capacity ($\frac{LS}{2}$) in relationship to the weight of the cables and hoses contained per linear metre.

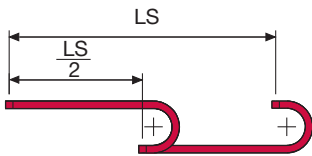
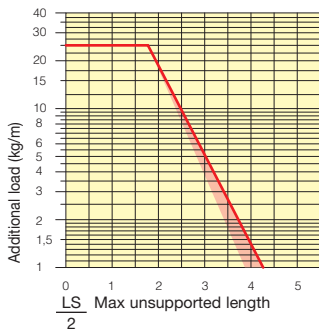

The red marking in the diagram area considers the difference of weight between various widths of chains assembled with nylon frames every second pitch.

For applications with $\frac{LS}{2}$ and weights not included in the area of the diagram showing self-supporting capacity, verify the possible use of support rollers (see page 30).

End Brackets

The end brackets set allows the two ends of the chain to be attached to the equipment. Set complete with tiewrap clamps available on request.

Nylon Type

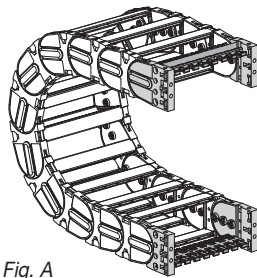
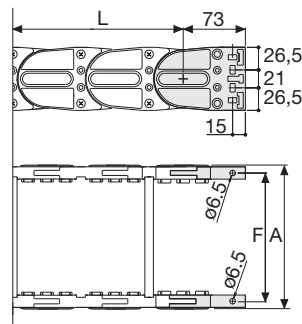

Fig. A
The chain can be fixed frontally, inner or outer radius. (Fig A)



Chain Type	F mm
308SU038	62
308SU049	73
308SU063	87
308SU069	93
308SU073	97
308SU083	107
308SU088	112
308SU095	119
308SU105	129
308SU113	137
308SU124	148
308SU138	162
308SU163	187
308SU188	212
308SU199	223
308SU213	237
308SU240	264
308SU249	273
308SU274	298
308SU300	324
308SU322	346
308SU350	374

Nylon Type Part Numbers

Complete Set Assembled	
Chain Type	End Brackets Set
308SU...	AN308SKM

Complete Set Unassembled	
Chain Type	End Brackets Set
308SU...	AN308SK

Tiewrap Clamp	
Assembl.	CFC308S □□□*KM
Unassembl.	CFC308S □□□*K

Bright Zinc Plated Steel Type***

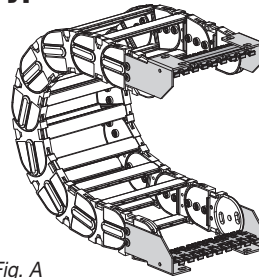
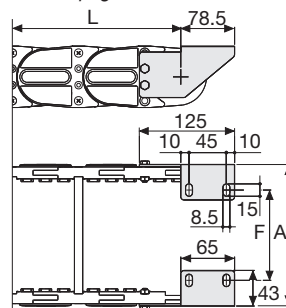

Fig. A
Chain fixed outside the radius. (Fig A)
See end brackets mounting variations page 31.



Chain Type	F mm
308SU038	-
308SU049	31
308SU063	45
308SU069	51
308SU073	55
308SU083	65
308SU088	70
308SU095	77
308SU105	87
308SU113	95
308SU124	106
308SU138	120
308SU163	145
308SU188	170
308SU199	181
308SU213	195
308SU240	222
308SU249	231
308SU274	256
308SU300	282
308SU322	304
308SU350	332

Bright Zinc Plated Steel Type Part Numbers

Complete Set Assembled	
Chain Type	End Brackets Set
308SU...	A308SKM □ **

Complete Set Unassembled	
Chain Type	End Brackets Set
308SU...	A308SK □ **

Tiewrap Clamp	
Assembl.	SFCT308S □□□*KM
Unassembl.	SFCT308S □□□*K

* Inner width (C)
** 1=Pos.1; 2=Pos.2; 3=Pos.3
*** Available on request in stainless steel

Serie Heavy

308SU

Nylon Cable Chain with opening frames

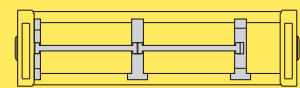

Separation System
To choose the separators see page. 216

How to open the cover.

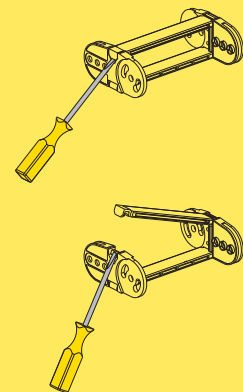

Protection version



Protection version
see page 148

For further information please consult Brevetti Stendaito's Technical Office

Serie Heavy

308B

Nylon Cable Chain with un-screwable aluminium rods

Inner height (D) 48 mm

Strong double share Sideband & Frame construction with large anti-friction triple-pin. Alu-rod frames are un-screwable from inner and outer radius. As standard the chain comes with frames every second link, on request with frames every link. Vertical and horizontal separator systems are available.

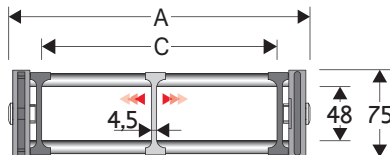

Separator

- Unassembled	Part.no S3000F
- Assembled	Part.no S3000FMC

Pin

Part.no PG308

Technical characteristics when self-supported

Speed	8 m/s
Acceleration	40 m/s ²

For higher requirements please consult our technical dept.

A	B	C	D	R	Weight/m	Chain
mm	mm	mm	mm	mm	kg	Part Number
156	75	100	48	150-180-200-230-280-300-400	2,85	308B100□*
206	75	150	48	150-180-200-230-280-300-400	3,00	308B150□*
256	75	200	48	150-180-200-230-280-300-400	3,15	308B200□*
306	75	250	48	150-180-200-230-280-300-400	3,30	308B250□*
356	75	300	48	150-180-200-230-280-300-400	3,45	308B300□*
C+56	75	48	150-180-200-230-280-300-400		308B□□□□**

*Complete the code by inserting the value of the radius (R): Ex. 308B200□

Where: 1=150; 2=180; 3=200; 4=230; 5=280; 6=400; 7=300

**Complete the code by inserting the value of the quote C and the radius (R): Ex. 308B□□□□□

Chain equipped with aluminium rods every pitch: complete the code by inserting the letter D.

Ex. 308B2001□

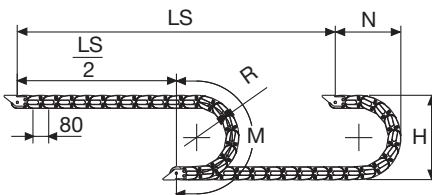

R	H	N	M
mm	mm	mm	mm
150	374	270	635
180	434	300	725
200	474	320	790
230	534	350	885
280	634	400	1040
300	675	420	1105
400	874	520	1420

Length of chain (L)

Half travel distance ($\frac{LS}{2}$) plus length of curve (M)

$$L = \frac{LS}{2} + M$$



Version with Alu-rods on every second pitch.

Serie Heavy

308E Nylon Cable Chain with alu-drawn frames

Inner height (D) 56,5 mm

Strong side-bands chain with dovetailed links and triple low friction pins. Alu-drawn frames mounted each second pitch full-pitch frames version available on demand.

Special C size available on demand. Vertical and horizontal separator systems are available.

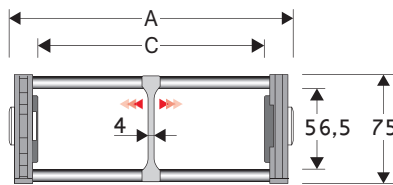

Separator

- Unassembled	Part.no S308EF
- Assembled	Part.no S308EFMC

Pin

Part.no PG308

Technical characteristics when self-supported

Speed	8 m/s
Acceleration	40 m/s ²

For higher requirements please consult our technical dept.

A	B	C	D	R	Weight/m	Chain
mm	mm	mm	mm	mm	kg	Part Number
144	75	100	56,5	135-150-180-200-230-280-300-400	2,85	308E100□□□*
194	75	150	56,5	135-150-180-200-230-280-300-400	2,95	308E150□□□*
244	75	200	56,5	135-150-180-200-230-280-300-400	3,05	308E200□□□*
294	75	250	56,5	135-150-180-200-230-280-300-400	3,15	308E250□□□*
344	75	300	56,5	135-150-180-200-230-280-300-400	3,25	308E300□□□*
C+44	75	56,5	135-150-180-200-230-280-300-400		308E□□□□□**

*Complete the code by inserting the value of the radius (R): Ex. 308E200[1][3][5]

**Complete the code by inserting the value of the quote C and the radius (R): Ex. 308E[1][2][3][7][3][5]
Chain equipped with alu-drawn frames full-pitch: complete the code by inserting the letter D.
Ex. 308E200135[1]

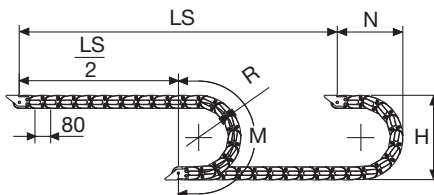

Length of chain (L)
Half travel distance ($\frac{LS}{2}$)
plus length of curve (M)

$$L = \frac{LS}{2} + M$$

R	H	N	M
mm	mm	mm	mm
135	345	255	585
150	375	270	635
180	435	300	730
200	475	320	790
230	535	350	885
280	635	400	1040
300	675	420	1105
400	875	520	1420



Self-Supporting Capacity Diagram

The maximum length of the self-supporting capacity ($\frac{LS}{2}$) in relationship to the weight of the cables and hoses contained per linear metre.

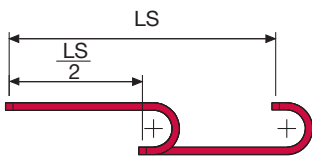
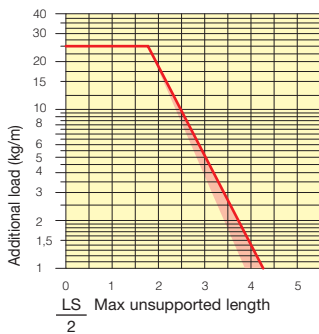

The red marking in the diagram area considers the difference of weight between various widths of chains assembled with alu-drawn frames every second pitch.

For applications with $\frac{LS}{2}$ and weights not included in the area of the diagram showing self-supporting capacity, verify the possible use of support rollers (see page 30).

End Brackets

The end brackets set allows the two ends of the chain to be attached to the equipment. Set complete with tiewrap clamps available on request.

Nylon Type

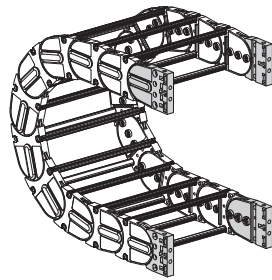

Fig. A
The chain can be fixed frontally, inner or outer radius. (Fig A)

Bright Zinc Plated Steel Type***

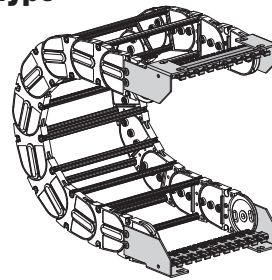
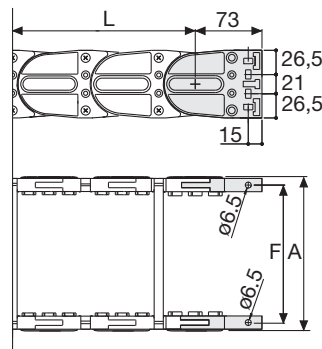

Fig. B
Chain fixed outside the radius. (Fig B)
See end brackets mounting variations page 31.



Chain Type	F mm
308E100	123
308E150	173
308E200	223
308E250	273
308E300	323
Special widths F=A-20	

Nylon Type Part Numbers

Complete Set Assembled	
Chain Type	End Brackets Set
308E...	AN308SKM

Complete Set Unassembled	
Chain Type	End Brackets Set
308E...	AN308SK

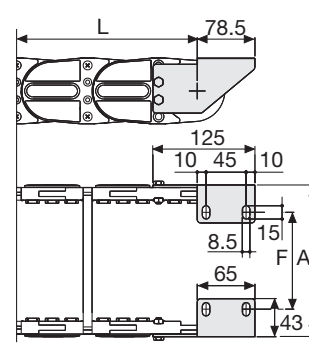

Chain Type	F mm
308E100	81
308E150	131
308E200	181
308E250	231
308E300	281
Special widths F=A-62	

Bright Zinc Plated Steel Type Part Numbers

Complete Set Assembled	
Chain Type	End Brackets Set
308E...	A308EKM□**

Complete Set Unassembled	
Chain Type	End Brackets Set
308E...	A308EK□**

Tiewrap Clamp
Assembl. SFCT308E□□□*KM
Unassembl. SFCT308E□□□*K
* Inner width (C)
** 1=Pos.1; 2=Pos.2; 3=Pos.3
*** Available on request in stainless steel

Serie Heavy

308E

Nylon Cable Chain with alu-drawn frames

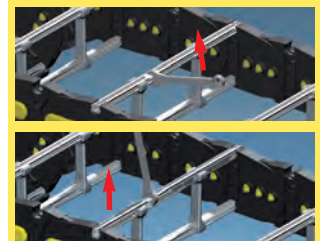

How to open alu-drawn frames

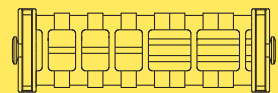

Supplementary movable separators.

Special tool to remove the connecting pivots:
Part Number PZ038



For further information please consult Brevetti Stendaito's Technical Office

Serie Heavy

309SU

Nylon Cable Chain with opening frames

Inner height (D) 75,5 mm

Strong double share Sideband & Frame construction with large anti-friction triple-pin. Frames opening from inner and outer radius.

As standard the chain comes with frames every second link, on request with frames every link.

Vertical and horizontal modular separator system is available.

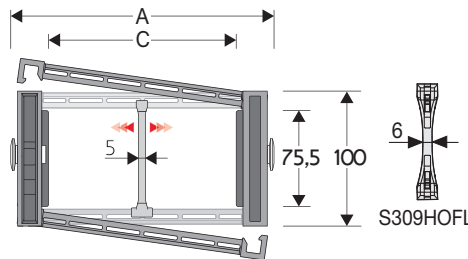

Separator

- Unassembled	Part.no S309S/3178
- Assembled*	Part.no S309S/3178MCI
- Assembled**	Part.no S309S/3178MCE

Strong-hold separator

for C > 250 mm

- Unassembled	Part.no S309HOFL
- Assembled	Part.no S309HOFLMC

Pin

	Part.no PG309H
--	----------------

* for chain opening outer radius

** for chain opening inner radius

Technical characteristics when self-supported

Speed	8 m/s
Acceleration	40 m/s ²

For higher requirements please consult our technical dept.

A	B	C	D	R	Weight/m	Chain
mm	mm	mm	mm	mm	kg	Part Number
117	100	64	75,5	150-200-250-300-350-400-500-600	4,03	309SU064□□□*
137	100	84	75,5	150-200-250-300-350-400-500-600	4,09	309SU084□□□*
162	100	109	75,5	150-200-250-300-350-400-500-600	4,17	309SU109□□□*
169	100	116	75,5	150-200-250-300-350-400-500-600	4,20	309SU116□□□*
192	100	139	75,5	150-200-250-300-350-400-500-600	4,27	309SU139□□□*
232	100	179	75,5	150-200-250-300-350-400-500-600	4,40	309SU179□□□*
267	100	214	75,5	150-200-250-300-350-400-500-600	4,51	309SU214□□□*
293	100	240	75,5	150-200-250-300-350-400-500-600	4,60	309SU240□□□*
317	100	264	75,5	150-200-250-300-350-400-500-600	4,67	309SU264□□□*
343	100	290	75,5	150-200-250-300-350-400-500-600	4,75	309SU290□□□*
367	100	314	75,5	150-200-250-300-350-400-500-600	4,83	309SU314□□□*
393	100	340	75,5	150-200-250-300-350-400-500-600	4,90	309SU340□□□*
417	100	364	75,5	150-200-250-300-350-400-500-600	4,99	309SU364□□□*
472	100	419	75,5	150-200-250-300-350-400-500-600	5,20	309SU419□□□*
541	100	488	75,5	150-200-250-300-350-400-500-600	5,40	309SU488□□□*

*Complete the code by inserting the value of the radius (R): Ex. 309SU116 □□□□

Chain equipped with nylon frame every pitch: complete the code by inserting the letter D.
Ex. 309SU116250 □□

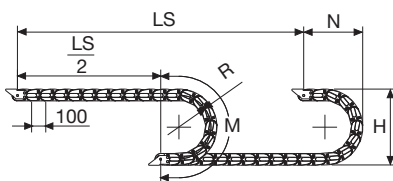

Length of chain (L)

Half travel distance ($\frac{LS}{2}$)
plus length of curve (M)

$$L = \frac{LS}{2} + M$$

R	H	N	M
mm	mm	mm	mm
150	406	300	675
200	506	350	830
250	606	400	985
300	706	455	1145
350	806	500	1300
400	906	555	1460
500	1106	650	1770
600	1306	750	2085



Self-Supporting Capacity Diagram

The maximum length of the self-supporting capacity ($\frac{LS}{2}$) in relationship to the weight of the cables and hoses contained per linear metre.

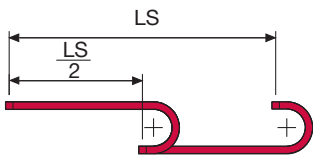
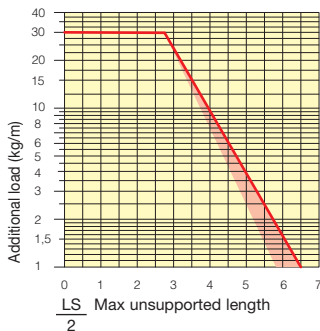

The red marking in the diagram area considers the difference of weight between various widths of chains assembled with nylon frames every second pitch.

For applications with $\frac{LS}{2}$ and weights not included in the area of the diagram showing self-supporting capacity, verify the possible use of support rollers (see page 30).

End Brackets

The end brackets set allows the two ends of the chain to be attached to the equipment. Set complete with tie-wrap clamps available on request.

Nylon Type

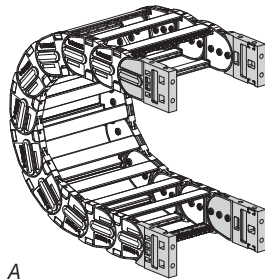
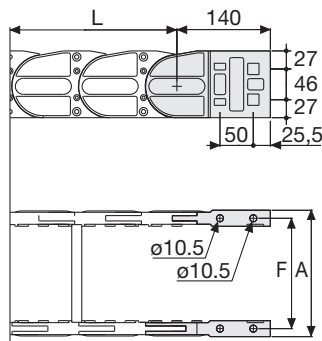

Fig. A
The chain can be fixed frontally, inner or outer radius. (Fig A)



Chain Type	F mm
309SU064	92
309SU084	112
309SU109	137
309SU116	144
309SU139	167
309SU179	207
309SU214	242
309SU240	268
309SU264	292
309SU290	318
309SU314	342
309SU340	368
309SU364	392
309SU419	447
309SU488	516

Nylon Type Part Numbers

Complete Set Assembled	
Chain	End Brackets
Type	Set
309SU...	AN309KM
Complete Set Unassembled	
Chain	End Brackets
Type	Set
309SU...	AN309K
Tiewrap Clamp	
Assembl.	CFC309S □□□*KM
Unassembl.	CFC309S □□□*K

Bright Zinc Plated Steel Type***

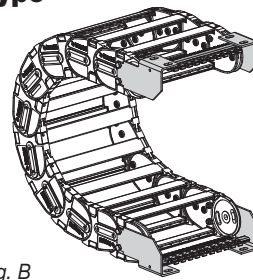
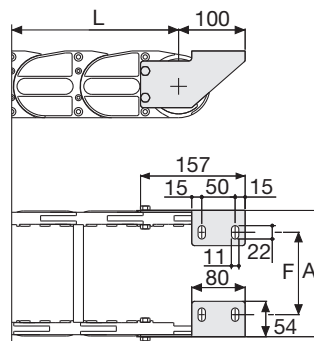

Fig. B
Chain fixed outside the radius. (Fig B)
See end brackets mounting variations page 31.



Chain Type	F mm
309SU064	50
309SU084	70
309SU109	95
309SU116	102
309SU139	125
309SU179	165
309SU214	200
309SU240	226
309SU264	250
309SU290	276
309SU314	300
309SU340	326
309SU364	350
309SU419	405
309SU488	474

Bright Zinc Plated Steel Type Part Numbers

Complete Set Assembled	
Chain	End Brackets
Type	Set
309SU...	A309SKM □**
Complete Set Unassembled	
Chain	End Brackets
Type	Set
309SU...	A309SK □**
Tiewrap Clamp	
Assembl.	SFCT309S □□□*KM
Unassembl.	SFCT309S □□□*K

* Inner width (C)
** 1=Pos.1; 2=Pos.2; 3=Pos.3
*** Available on request in stainless steel

Serie Heavy

309SU

Nylon Cable Chain with opening frames

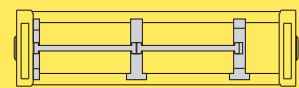

Separation System To choose the separators see page 216

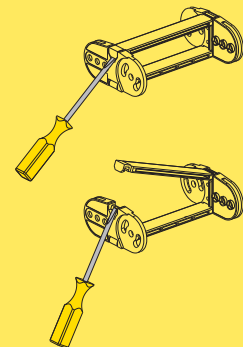

How to open the cover.

Protection version

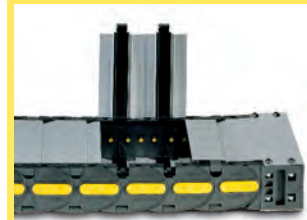

Protection version see page 152

For further information please consult Brevetti Stendalto's Technical Office

Self-Supporting Capacity Diagram

The maximum length of the self-supporting capacity ($\frac{LS}{2}$) in relationship to the weight of the cables and hoses contained per linear metre.

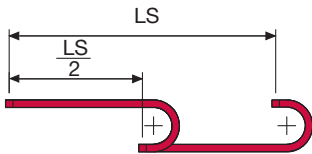
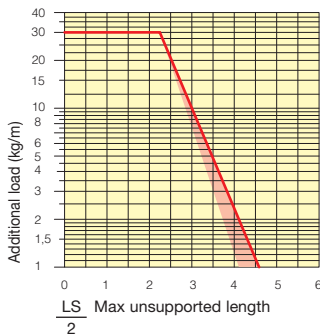

The red marking in the diagram area considers the difference of weight between various widths of chains assembled with rods every second pitch.

For applications with $\frac{LS}{2}$ and weights not included in the area of the diagram showing self-supporting capacity, verify the possible use of support rollers (see page 30).

End Brackets

The end brackets set allows the two ends of the chain to be attached to the equipment. Set complete with tie-wrap clamps available on request.

Nylon Type

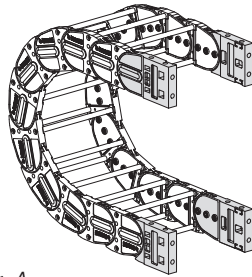

Fig. A The chain can be fixed frontally, inner or outer radius. (Fig A)

Bright Zinc Plated Steel Type***

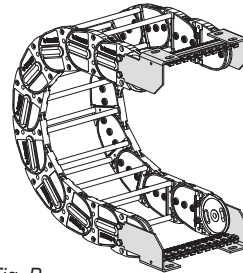
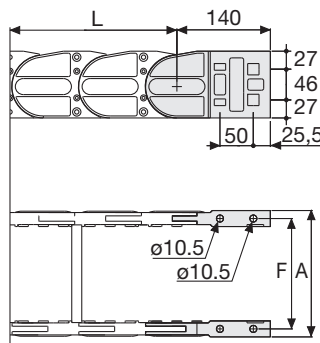

Fig. B Chain fixed outside the radius. (Fig B) See end brackets mounting variations page 31.



Chain Type	F mm
309B100	129
309B150	179
309B200	229
309B250	279
309B300	329
309B400	429

Special widths F=A-24

Nylon Type Part Numbers

Complete Set Assembled	
Chain Type	End Brackets Set
309B...	AN309KM

Complete Set Unassembled	
Chain Type	End Brackets Set
309B...	AN309K

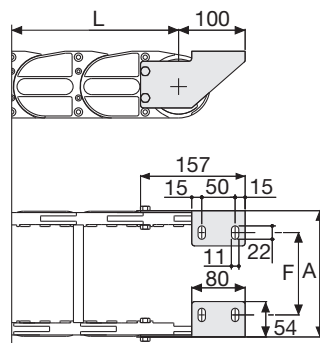

Chain Type	F mm
309B100	87
309B150	137
309B200	187
309B250	237
309B300	287
309B400	387

Special widths F=A-66

Bright Zinc Plated Steel Type Part Numbers

Complete Set Assembled	
Chain Type	End Brackets Set
309B...	A309KM □**

Complete Set Unassembled	
Chain Type	End Brackets Set
309B...	A309K □**

Tiewrap Clamp
 Assembl. SFCT309B □□□*KM
 Unassembl. SFCT309B □□□*K
 * Inner width (C)
 ** 1=Pos.1; 2=Pos.2; 3=Pos.3
 *** Available on request in stainless steel

Serie Heavy

309B Nylon Cable Chain with un-screwable aluminium rods

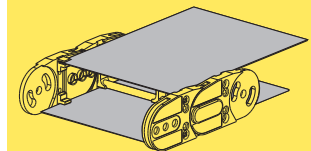

Steel laminar cover.

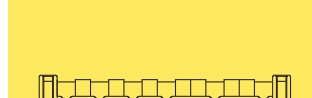

Supplementary movable separators.

Version with aluminium draw plates



On request available with aluminium draw plates

Example Part Number:
309T □□□*□□□**

* Inner width (C)
 ** Bending radius (R)

For further information please consult Brevetti Stendalto's Technical Office